

# ASYLUM

Car Audio

## OWNER'S MANUAL

**CFAM5860**

— CAR AUDIO SYSTEM —  
PLEASE READ CAREFULLY BEFORE INSTALLING  
OR OPERATING THIS UNIT

### **WARNING**

Make sure you choose a suitable place to mount the unit. The position should be completely dry with a good circulation of air, and from a mechanical point of view very stable.

## System planning

Proper system planning is the best way to maximize your amplifier performance. By planning your installation carefully you can avoid situations where the performance of the reliability of your system is compromised. Your authorized dealer has been trained to maximize your system's sonic potential. Your dealer is a valuable resource in helping you with your system design and installation.

### Speaker requirements

Each channel of your amplifier can easily drive 4Ω speaker loads when used in the stereo mode. When a channel-pair is bridged, the recommended minimum load impedance is 3Ω for subwoofer use, and 4Ω for full range operation. Although operation with lower impedances is not likely to cause immediate damage to the internal circuitry, the unit will most likely overheat, causing the thermal protection circuitry to shut down the amplifier. When the chassis cools down, normal operation will resume. Continuing to operate the amplifier under these conditions is not recommended and will reduce its life expectancy.

Most subwoofers designed for car audio operation are 4Ωhm impedance. Connecting two such speakers in parallel will result in a 2Ωhm impedance load as seen by the amplifier. Some subwoofer models feature a dual 4Ωhm voice coil design. Connecting these voice coils in parallel will result in a 2Ωhm nominal impedance. Connecting two 4Ωhm coils in Series (either with two 4Ωhm subs or one dual 4Ωhm sub ) will result in an 8Ωhm load.

Other subwoofers designed for car audio operation are 2Ωhm impedance. Connecting two such speakers in parallel will result in a 1Ωhm impedance load as seen by the amplifier. Some subwoofer models feature a dual 2Ωhm voice coil design. Connecting these voice coils in parallel will also result in a 1Ωhm nominal impedance.

Wiring two 2Ωhm coils in Series (either with two 2Ωhm subs or one dual 2Ωhm sub ) will result in an 4Ωhm load.

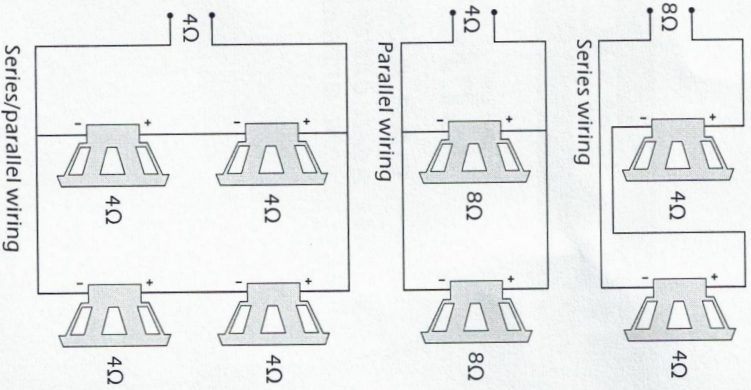

## Power Connection Leads

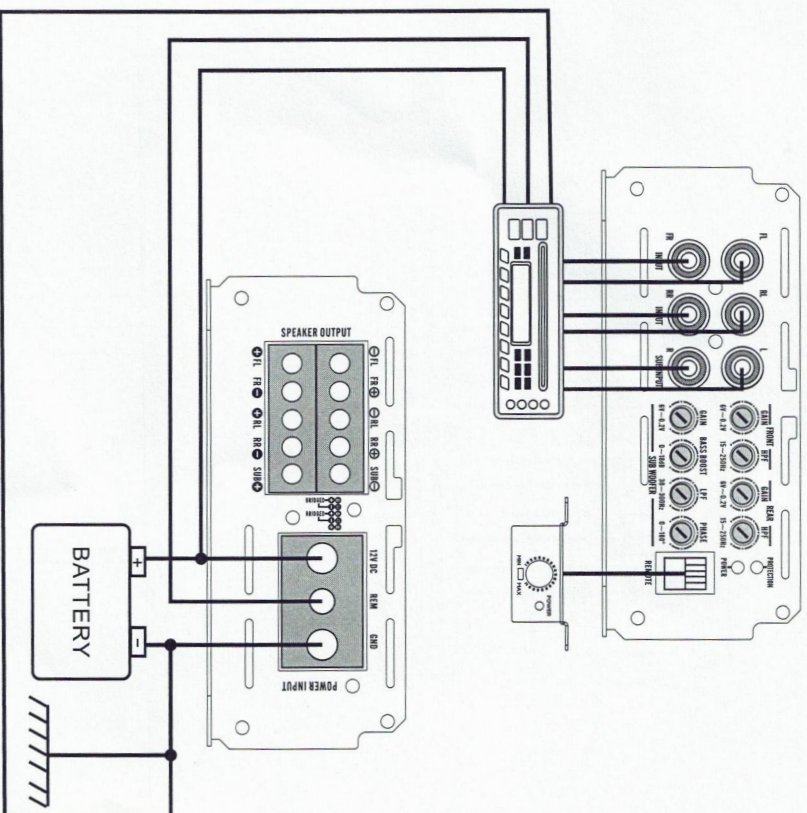

## Notes on the power supply

Connect the + 12V power input lead only after all other leads have been connected. Be sure to connect the ground wire of the unit securely to a BARE metal part of the car (scrape the paint off the spot where you connect the ground!).

A loose connection may cause a malfunction of the amplifier. REMOTE: The unit is turned on by applying + 12Volts to this terminal. This terminal does not draw heavy current like the two power terminal so a thinner connecting wire is acceptable. Standard 18 GAUGE is fine and the standard color is blue. If the radio is equipped with a power antenna control wire, it can drive this terminal. If the power antenna wire is already in use, you can still splice into it.

Place the fuse in the power supply lead as close as possible to the car battery. During a full power operation, Maximum current will run through the system. Therefore, Make sure the that the leads to be connected to the + 12v and GND terminals of the unit respectively must be larger than 8-Gauge (AWG. 8).



# Troubleshooting

symptom	possible cause	action to take
no output	low or no remote turn-on input	check remote turn-on voltage output at amplifier and correct as needed
	fuse blown	check power wire integrity and reversed polarity, repair as needed and replace fuse
	power wires not connected	check power wire and ground connections and repair or replace as needed
	audio input not connected or no output from source	check input connections and signal integrity, repair or replace as needed
	speaker wires not connected	check speaker wires and repair or replace as needed
audio cycles on and off	speakers are blown	check system with known working speaker and repair or replace speakers as needed
	thermal protection engages when amplifier heatsink temperature exceeds 194°F	make sure there is proper ventilation for amplifier and improve ventilation as needed
	loose or poor audio input	check input connections and repair or replace as needed
distorted output	amplifier level sensitivity set too high; exceeding maximum output capability of amplifier	reset gain referring to the tuning section of the manual for detailed instructions
	impedance load to amplifier too low	check speaker impedance load if below 2Ω stereo or 4Ω mono rewrite speakers to achieve a higher impedance
	shorted speaker wires	check speaker wire connections and repair or replace as needed
	speaker not connected to amplifier properly	check speaker wiring and repair or replace as needed refer to the installation section of this manual for detailed instructions

Symptom	possible cause	action to take
distorted output (cont'd)	internal crossovers not set properly for speaker	reset crossovers referring to the multi-cross crossover configuration section of this manual
	speakers are blown	check system with known working speakers and repair or replace as needed
poor bass response	speakers wired wrong polarity causing cancellation at low frequencies	check speaker polarity and repair as needed
	crossover set incorrectly	reset crossovers referring to the multi-cross crossover configuration section of this manual for detailed instructions
battery fuse blowing	impedance load to amplifier too low	check speaker impedance load, if below 2Ω stereo or 4Ω bridgedmono rewrite speakers to achieve a higher impedance
	short in power wire or incorrect power connections	check power and ground connections and repair as needed
	fuse used is smaller than recommended	replace with proper fuse size
	too much current being drawn	check speaker impedance load, if below 2Ω stereo or 4Ω mono rewrite speakers to achieve a higher impedance
	short in power wire or incorrect	check power and ground connections and repair as needed
amplifier fuse blowing	too much current being drawn	check speaker impedance load, if below 2Ω stereo or 4Ω mono rewrite speakers to achieve a higher impedance and replace with recommended fuse size
	fuse used is smaller than recommended	check power and ground connections and repair as needed replace with proper fuse size

# Specifications

## Amplifier section

Power output 4 $\Omega$ (watts)	80W X 4 CH+300W X 1 CH
Power output BTL(watts)	220W X 2 CH
Power output 2 $\Omega$ (watts)	110W X 4 CH + 500W X 1 CH
THD	$\leq 0.2\%$
frequency response ( $\pm 2dB$ )	CH1 ~CH4: 20Hz~20KHz CH5: 10Hz~250Hz
signal to noise ratio	$\geq 90dB$
sensitivity	0.2~6V
recommended fuse type	35A X 3
dimensions	10.11in X 5.04in X 2.34in

Features and specifications subject to change and/or improvement without notice