

DRONE[®] XC

User Guide

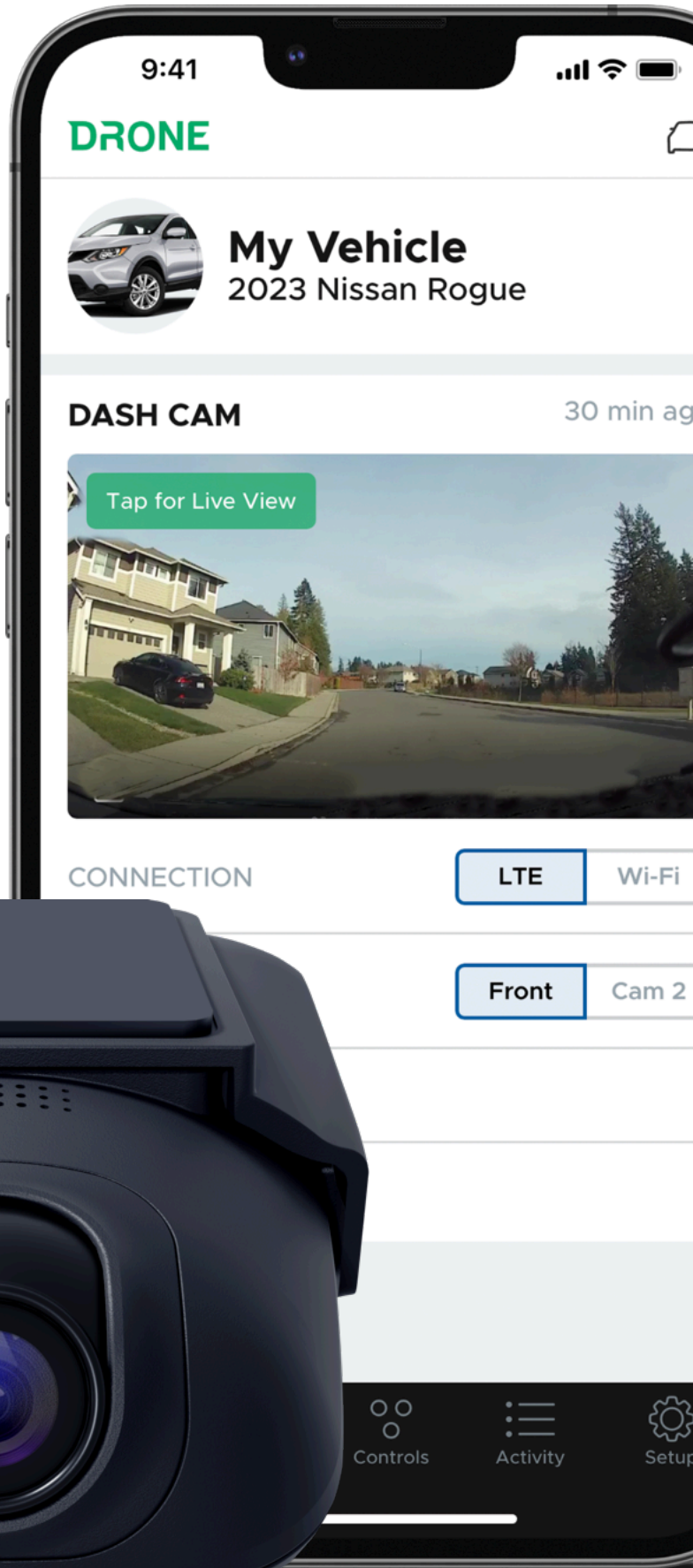

Table of Contents

1	Contents	1
2	Specs	2
3	Installation	3
3.1	Where to Buy	3
3.2	Installation Types	3
3.3	Basic Connections	3
3.4	Compatibility	3
4	Setup	4
4.1	Download the DroneMobile App	4
4.2	Account Registration	4
4.3	Selecting Your DroneMobile Plan	7
4.4	Onboarding	10
4.5	Dash Cam Settings	10
4.6	Firmware Update	12
5	Basic App Functions	15
5.1	Home	15
5.2	Tracking	15
5.3	Controls	16
5.4	Activity	16
5.5	Setup	17
6	Recording Modes	18
6.1	Driving Mode	18
6.2	Parking Mode	18

6.3	Manual	20
7	Live View	21
7.1	Live View via LTE	21
7.2	Live View via Wi-Fi	22
7.3	Live View Controls	24
7.4	Live View from Secondary Camera	25
8	Gallery	27
8.1	Cloud	28
8.2	SD Card	30
8.3	Media Download Queue	32
8.4	Filters	32
9	Download Media	34
9.1	Download Media via LTE on the "Gallery"	34
9.2	Download Media via LTE on the "Feed"	36
9.3	Download Media via Wi-Fi on the "Gallery"	37
9.4	Downloading Media via Micro SD-Card	39
10	Warranty	41
11	Troubleshooting	42
11.1	Wi-Fi Issues	42
11.2	Gallery/Media Issues	42
11.3	Miscellaneous Issues	42
11.4	Secondary Not Camera Displaying	43
12	Contact	44

1 | Contents



XC Front Camera



Windshield Mount



Install Harness



64GB Micro SD Card



Harness Cover



Screwdriver



Screws (2)



Door Jamb Sticker



Cleaning Swab



Quick Card



Free 30-Day Trial



IR1 Interior Camera
(Sold Separately)



IR1 Interior Camera
(Sold Separately)

2 | Specs

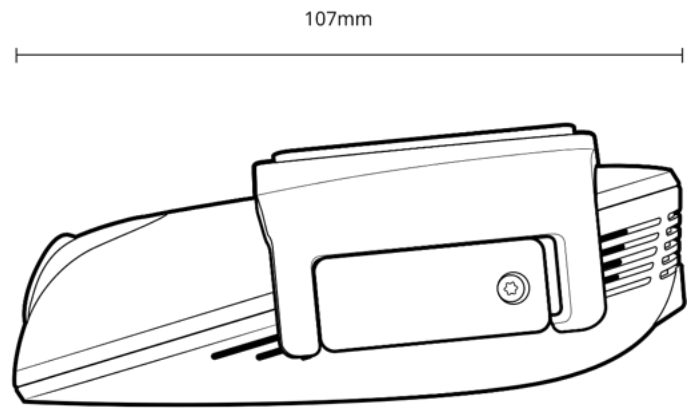
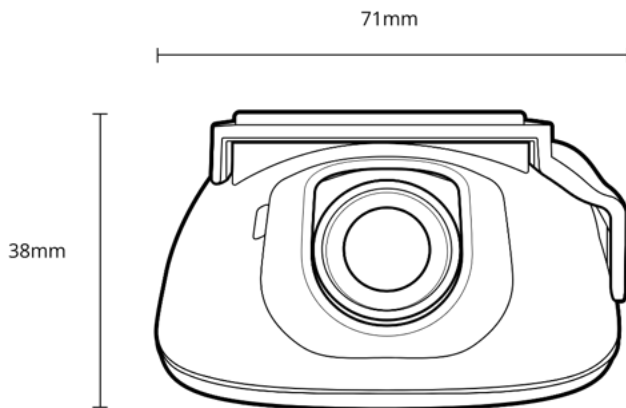

Image Resolution	2K QHD (1440p) Front Camera
Live Stream Resolution	540p
Video Channels	Up to 2, including front camera
Frames/sec	30fps
Image Sensor	Sony STARVIS
File Format	.mp4
LTE Connectivity	Yes
Wi-Fi Connectivity	Yes
GPS Location	Yes
Microphone	Yes
Internal Speaker	Yes
Recording Modes	Driving, Event, Parking with Motion, Parking with Timelapse, Parking with Alerts,
Security Sensors	Shock, Tilt, Glass-Break, Motion, Door, Hood, Trunk
SD Card	64GB, Upgradeable to 512GB
Install Methods	Standalone or Data-to-Data

3 | Installation

3.1 | Where to Buy

DroneMobile products are sold and installed exclusively at authorized dealers across North America. To find an authorized dealer near you, please visit www.dronemobile.com.

3.2 | Installation Types

- **Standalone Mode** - Install Drone XC as a standalone LTE/Wi-Fi dash cam with GPS tracking capabilities to monitor speed, location, battery voltage, and more!
- **Data-to-Data Mode** - Connect Drone XC to a compatible Firstech remote start or security system to enjoy the convenience of unlimited-range vehicle control and monitoring.

3.3 | Basic Connections

- All Drone XC installations will require constant power (12v) and ground connections to sufficiently power the device.
- If installed in standalone mode, an additional connection to ignition is required.
- If installed in Data-to-Data Mode, Drone XC will connect to the RS-232 data port on the Firstech remote start or security control module.

3.4 | Compatibility

Drone XC works with all current Firstech remote start and security brands, including Compustar, Arctic Start, Nustart, FTX, and iDatastart.

Compatible Control Modules:

- Firstech CM-X
- Firstech CM-9 Series
- Firstech DC3 Series
- Firstech CM-2400/CM-2500 Series
- iDatastart HCX Series
- iDatastart VWX
- iDatastart BMX

4 | Setup

4.1 | Download the DroneMobile App

Once you've gotten your Drone XC installed by an authorized dealer, download the DroneMobile App on your smartphone from the App Store or Google Play.

4.2 | Account Registration

1. If you're a first-time DroneMobile user you will have to create an account. You can do so by opening the DroneMobile App and tapping on the "Register" link on the "Log In" page.

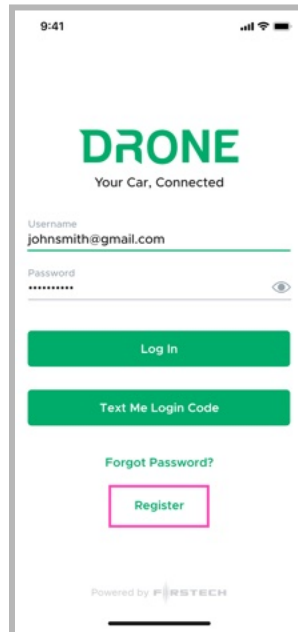

2. You will be prompted to enter your DroneMobile system serial number.

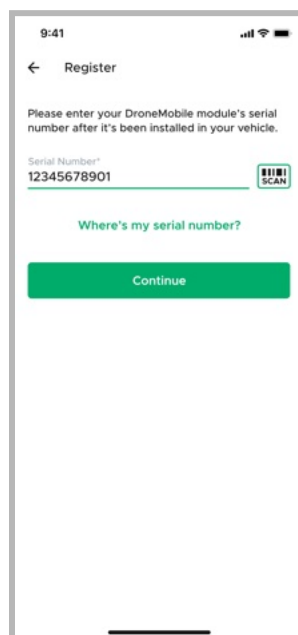

(Please note: At the time of installation, your authorized DroneMobile installer should have provided you with a few materials where you can locate your DroneMobile system's serial number)

- **Keychain Tag** - DroneMobile systems come with a keychain tag that your DroneMobile installer should have attached to your keychain or remote fob. This keychain tag has your system's serial number and barcode, which you can easily scan from the DroneMobile app.
- **Door Jamb Sticker** - As a backup, your DroneMobile installer may also place a sticker with your system's serial number to the driver's side door jamb, which is the area that connects your door to the vehicle body.
- **On the Drone XC Dash Cam itself** - All Drone XC Dash Cams have a label with your system's serial number. Remove the dash cam from the mounting bracket to access the label.
- **Bill of Sale** - As a last resort, check your bill of sale from your DroneMobile retailer, as your serial number may have been included on that document as well.

3. Next, you will be prompted to enter your personal information.

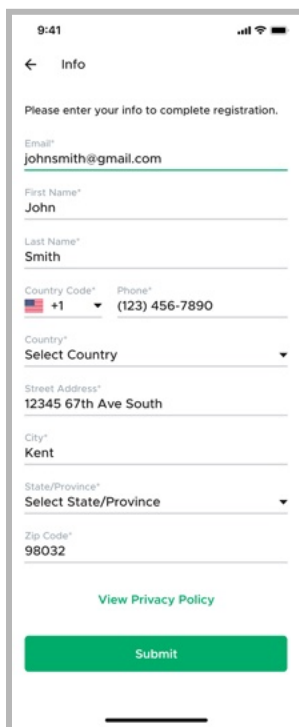

The image shows a mobile app registration screen titled "Info". At the top, it says "Please enter your info to complete registration." The form contains the following fields and values:

- Email***: johnsmith@gmail.com
- First Name***: John
- Last Name***: Smith
- Country Code***: +1 (with a US flag icon)
- Phone***: (123) 456-7890
- Country***: Select Country (dropdown menu)
- Street Address***: 12345 67th Ave South
- City***: Kent
- State/Province***: Select State/Province (dropdown menu)
- Zip Code***: 98032

Below the form, there is a link for "View Privacy Policy" and a green "Submit" button.

4. A confirmation email will be sent containing a link to set up a secure password.

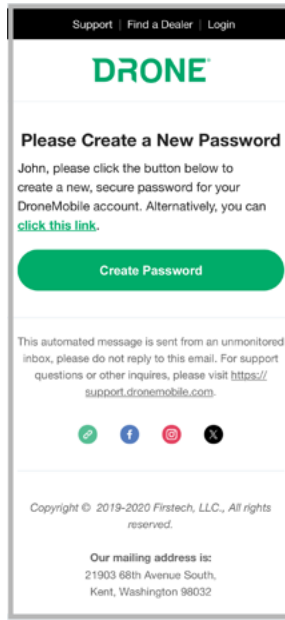

5. Follow the on-screen instructions to create a secure password.

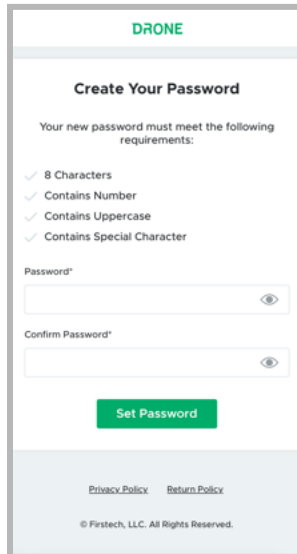

- Once you create a password, you will be prompted to log into accounts.dronemobile.com.

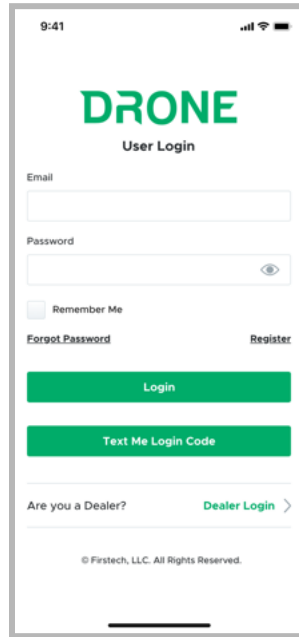

4.3 | Selecting Your DroneMobile Plan

Drone XC comes with a Free 30-Day Premium Trial which gives you access to Vehicle Control, Security, and GPS Tracking. The trial also includes remote live streaming from your dash cam and cloud storage for all your media. You can purchase a subscription prior to trial expiring for uninterrupted service.

- Log into accounts.dronemobile.com and navigate to the “Subscriptions” page. Click “Add Plan” or “Update Plan” by your desired vehicle

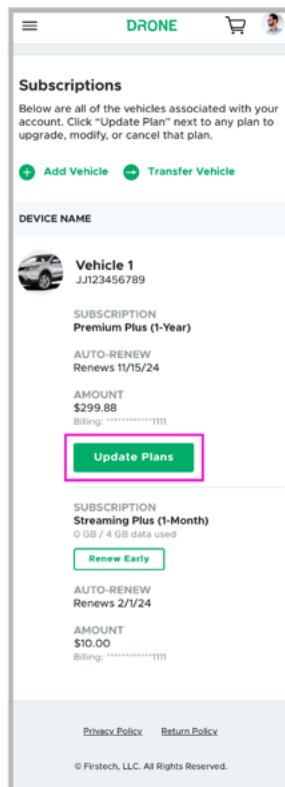

2. Select a DroneMobile plan.

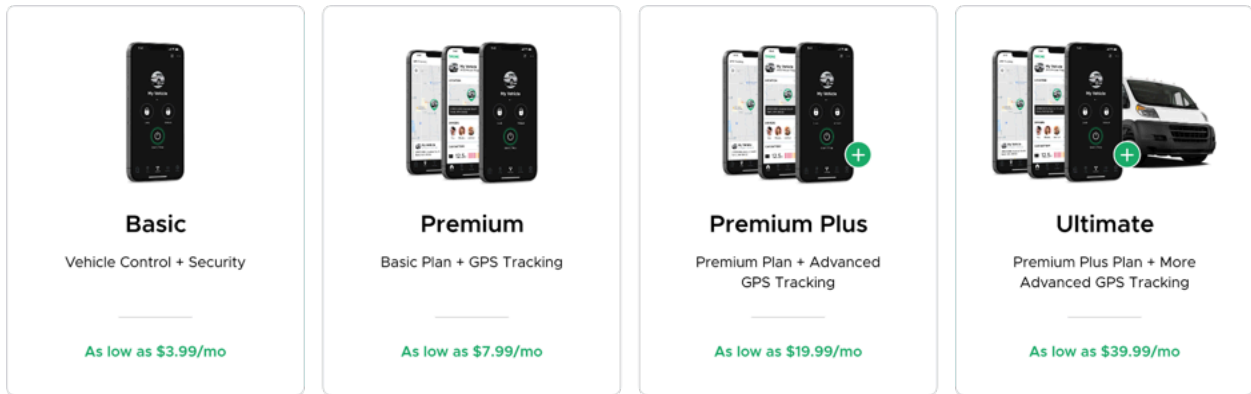
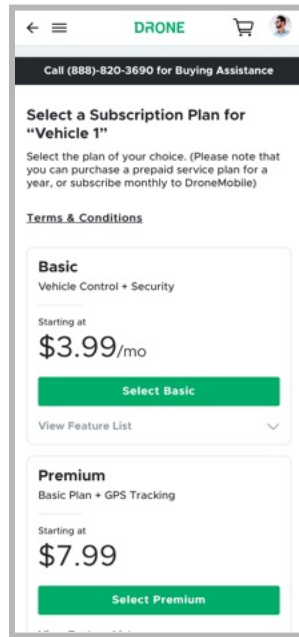

3. Then select a term length. (Longer term lengths offer greater savings)

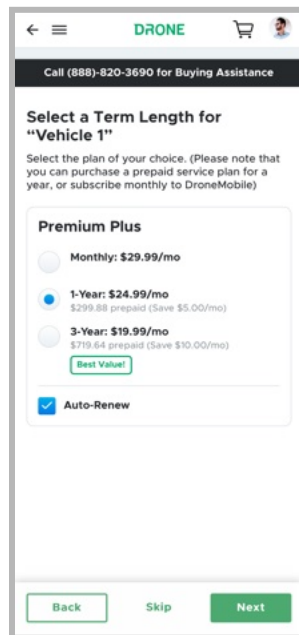

4. Afterwards, select your “Streaming Plan”.

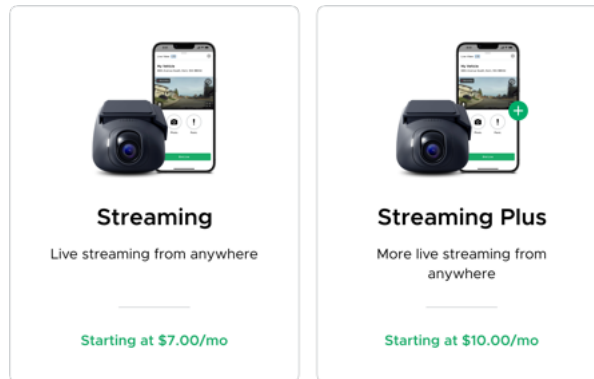
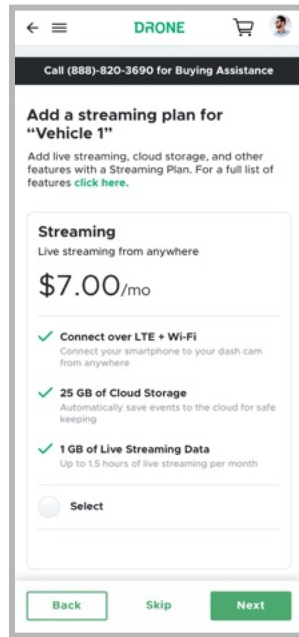

Plan Features:

No Streaming

- Connect via Wi-Fi
- Free

Streaming*

- Connect over LTE & W-Fi
- 1GB of Live Streaming data
- 25GB of cloud storage
- \$7/month OR Free with Premium Plus and Ultimate Plans

Streaming Plus*

- Connect over LTE & W-Fi
- 2GB of Live Streaming data
- 50GB of cloud storage
- \$10/month OR \$3 with Premium Plus and Ultimate Plans

*DroneMobile Plan required

5. Lastly, enter your billing info and click “Submit Payment”.

4.4 | Onboarding

The first time you log into the DroneMobile App you will be guided through the onboarding steps. Follow the onscreen instructions to set up your vehicle profile and account profile/settings. You will then be guided through the steps for connecting to your dash cam's Wi-Fi for the first time.

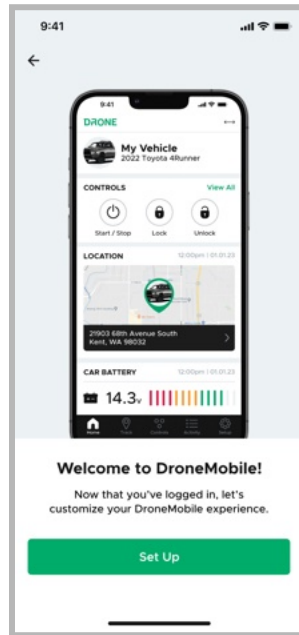

4.5 | Dash Cam Settings

Drone XC Dash Cam Settings are accessible through the "Dash Cam" widget on the "Home" page.

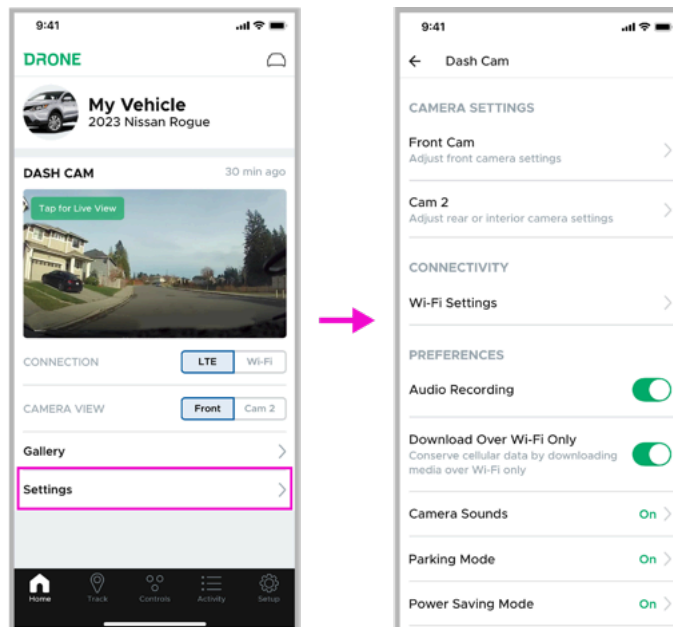

They are also accessible by going to Setup > Vehicles > [Select a Vehicle] > Dash Cam.

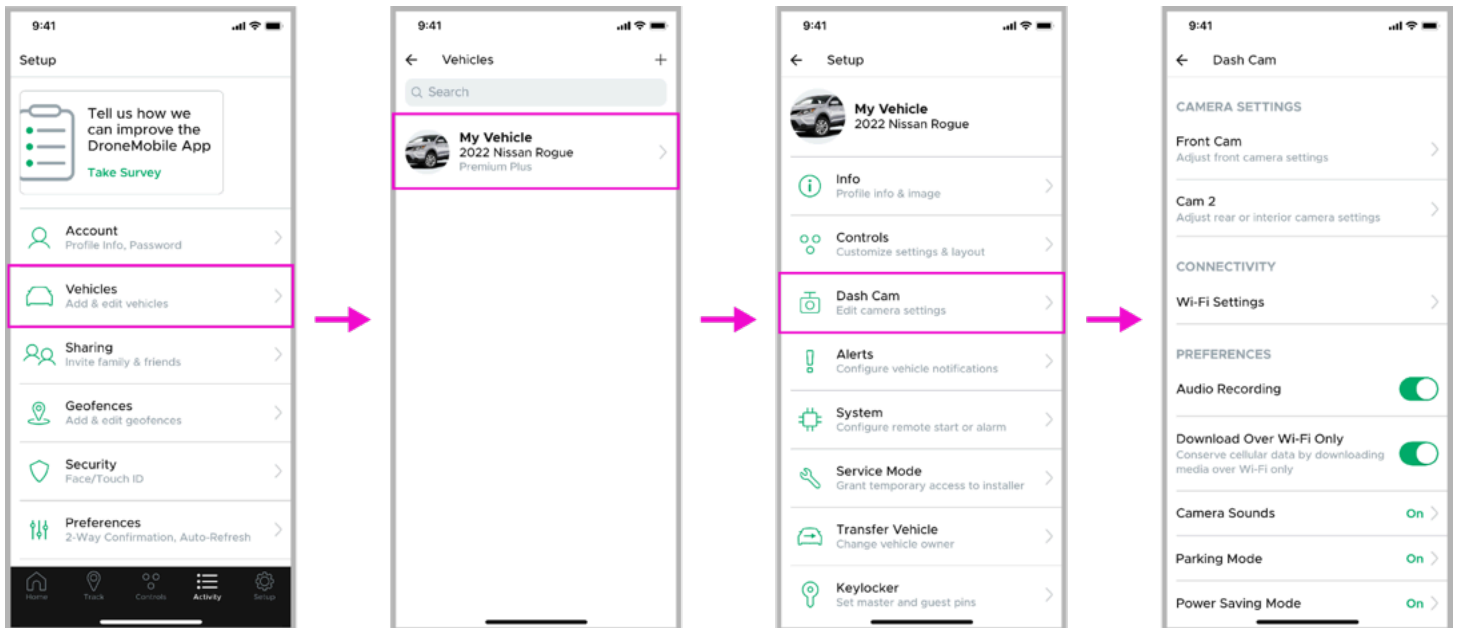

Dash Cam Settings Breakdown:

Camera Settings

- Front Cam - View a camera preview for the front camera
- Cam 2 (if installed) - View a camera preview for the rear or interior camera

Connectivity

- Wi-Fi - Set the SSID and password. (Please note: this is only available to customers with a “Streaming Plan”)

Preferences

- Audio Recording - Enable/disable the dash cam’s microphone when recording video
- Download Over Wi-Fi Only - Enable/disable media downloads over Wi-Fi only to conserve cellular data
- Camera Sounds - Enable/disable camera sounds and adjust the volume
- Parking Mode - Enable/disable video recording and select how your dash cam records while your vehicle is parked
- Power Saving Mode - Enable/disable conserving your battery by temporarily turning off GPS and Wi-Fi while your vehicle is parked. You can also set the battery level at which this mode will turn on.
- Data Overlay - Select which information to display on top of video recordings

Sensors

- Driving Sensor - Adjust the sensitivity of Drone XC to events while driving from 1-5.
- Parking Sensor - Adjust the sensitivity of Drone XC to events while parked from 1-5.
- Shock Sensor - Enable/disable Drone XC’s ability to detect medium to severe impacts. Adjust the sensitivity from 1-7.
- Tilt Sensor - Enable/disable Drone XC’s ability to detect unauthorized tilting/towing. Adjust the sensitivity from 1-2.
- Window Break Sensor - Enable/disable Drone XC’s ability to detect the sound of breaking glass. Adjust the sensitivity from 1-9.

4.6 | Firmware Update

Firmware updates ensure your hardware will work with the latest software and security features. The DroneMobile Team will release firmware updates semi-regularly to improve functionality and address known issues.

If there is a critical firmware update, the DroneMobile Team will notify Drone XC users via e-mail, [Facebook](#), and [Instagram](#).

Details about these releases may also be listed on the DroneMobile Blog and Help Center.

[Important Notes Regarding Drone XC-LTE Firmware Updates](#)

1. In order to download certain Drone XC-LTE dash cam firmware updates, a "Streaming" or "Streaming Plus" plan is required.
2. If you do not have a "Streaming" or "Streaming Plus" plan, you can install the firmware update offline (instructions below).
3. Drone XC-LTE dash cam firmware update files can use about 60-70MB of 4G LTE data. This will count against the data caps included in your "Streaming" or "Streaming Plus" plan.

How to Update Drone XC-LTE Firmware from the DroneMobile App

If you have a "Streaming" or "Streaming Plus" plan, installing firmware updates for your Drone XC-LTE dash cam is the same process as updating other Drone products. If your DroneMobile device needs a firmware update, you will see a banner in your DroneMobile app on your smartphone. Please see the image below:

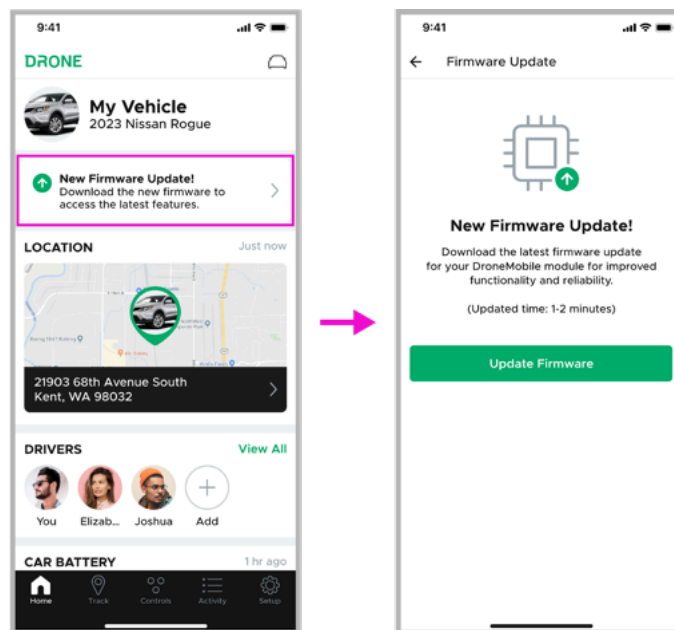

Once the firmware update is initiated, please allow up to 15 minutes for the update to complete. Please avoid using the Drone device while the firmware is updating. Once the 15 minutes has passed, please feel free to open your DroneMobile app and test the system.

How to Update Drone XC-LTE Firmware Offline without Streaming Subscription

If you do not have a "Streaming" or "Streaming Plus" plan OR you want to conserve your data usage, you can update your Drone XC dash cam's firmware offline.

(Please Note: This process must be completed on a desktop or tablet. Micro-SD card insert or adapter is required)

Please follow these steps to complete your Drone XC-LTE firmware update offline.

1. Remove the Micro-SD card from the Drone XC-LTE dash cam.
 - a. The Micro-SD card is located on the side of the Drone XC dash cam, underneath the security cover.

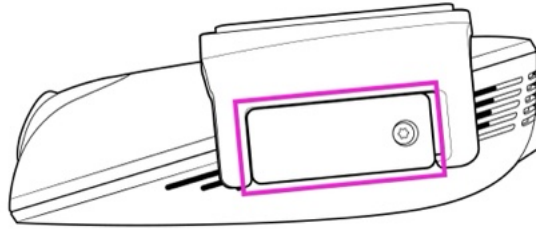

- b. Remove the security screw and the cover using the provided screwdriver



- c. Push the Micro-SD card in to eject the card from the camera.

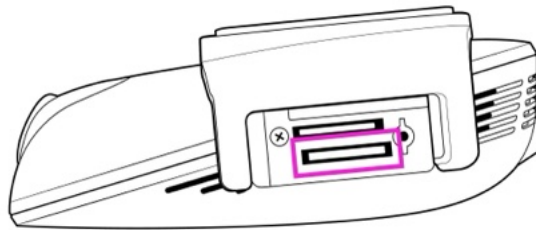

2. Insert the Micro-SD card into your desktop or tablet. (Micro-SD card adapter not included).
3. [Click this link](#) to download the .ZIP file containing the XC Firmware Update.
 - a. Or copy this URL into your internet browser: <https://xc-firmware.s3.amazonaws.com/xc-firmware.zip>
4. Extract the contents of the .ZIP file and copy them into the top-level, or root directory, of the Micro-SD card.
5. Safely eject the Micro-SD card from your desktop or tablet.
6. Re-insert the Micro-SD card into the Drone XC-LTE dash cam.
7. Power cycle your dash cam by pressing the button inside the pinhole on the side of your dash cam OR by disconnecting & reconnecting the power cable.
 - a. Alternatively, if you have a DroneMobile Basic/Premium plan, you can navigate to the "Dash Cam Settings" page and scroll to the bottom section named "Update Dash Cam"

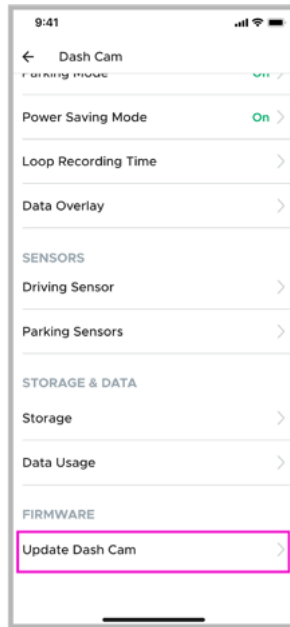

b. Select this item and then tap the button that says "Reboot Now".

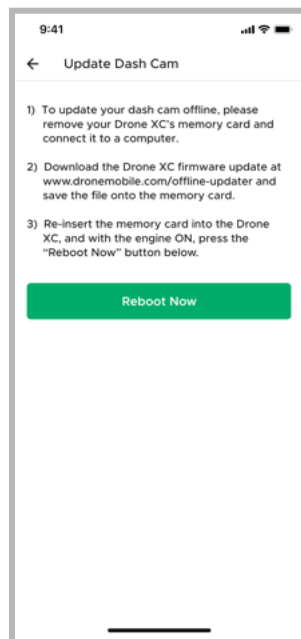

5 | Basic App Functions

5.1 | Home

The “Home” page gives you access to various widgets that display key information about your vehicle and other DroneMobile features. You can customize which widgets are shown via the “Edit” button at the bottom of the page.

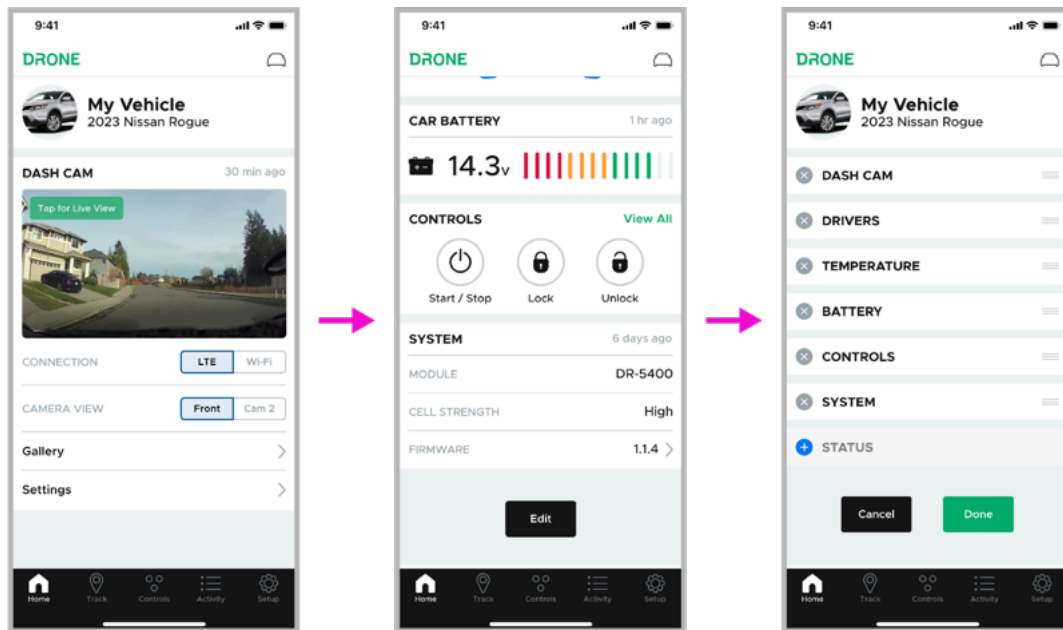

5.2 | Tracking

The “Tracking” page allows you to pinpoint your vehicle(s) exact location. Utilize geofences and POI's (Points of Interest) to receive alerts based on your vehicle's location.

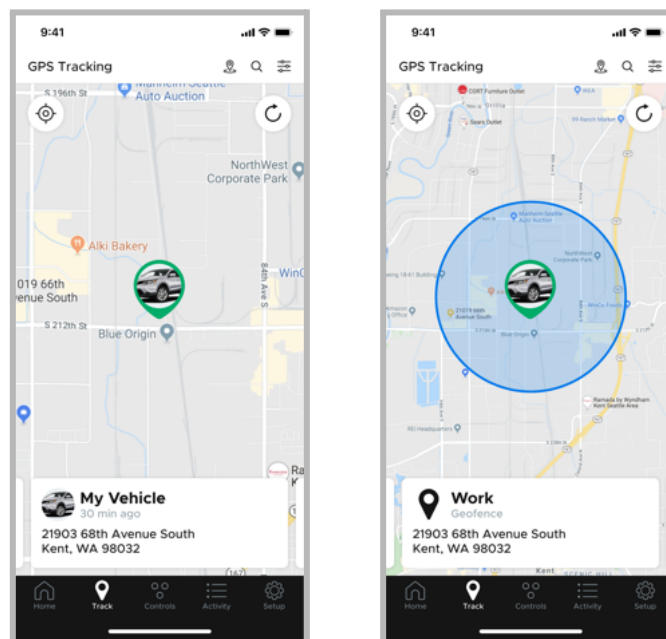

5.3 | Controls

The "Controls" page allows you to send commands to your vehicle from your smartphone. You can fully customize which buttons are displayed and how they are arranged.

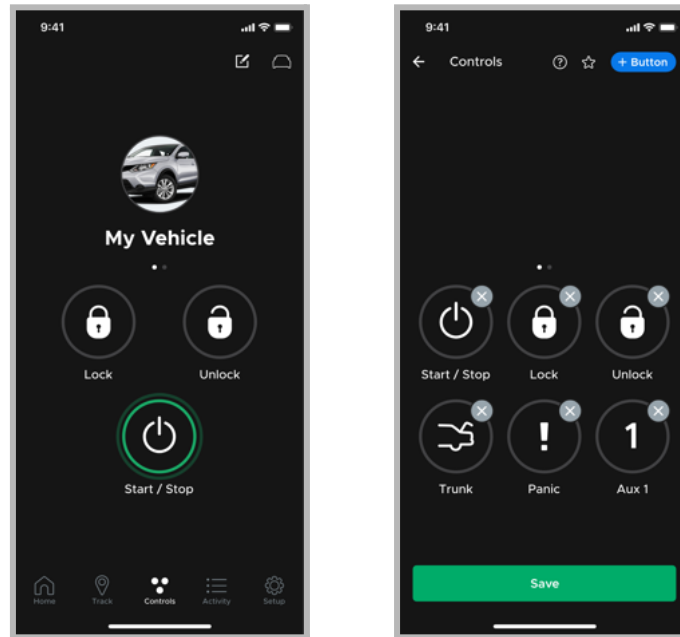

5.4 | Activity

The "Activity" page is a history log of dash cam media, events, and trips associated with your vehicle(s).

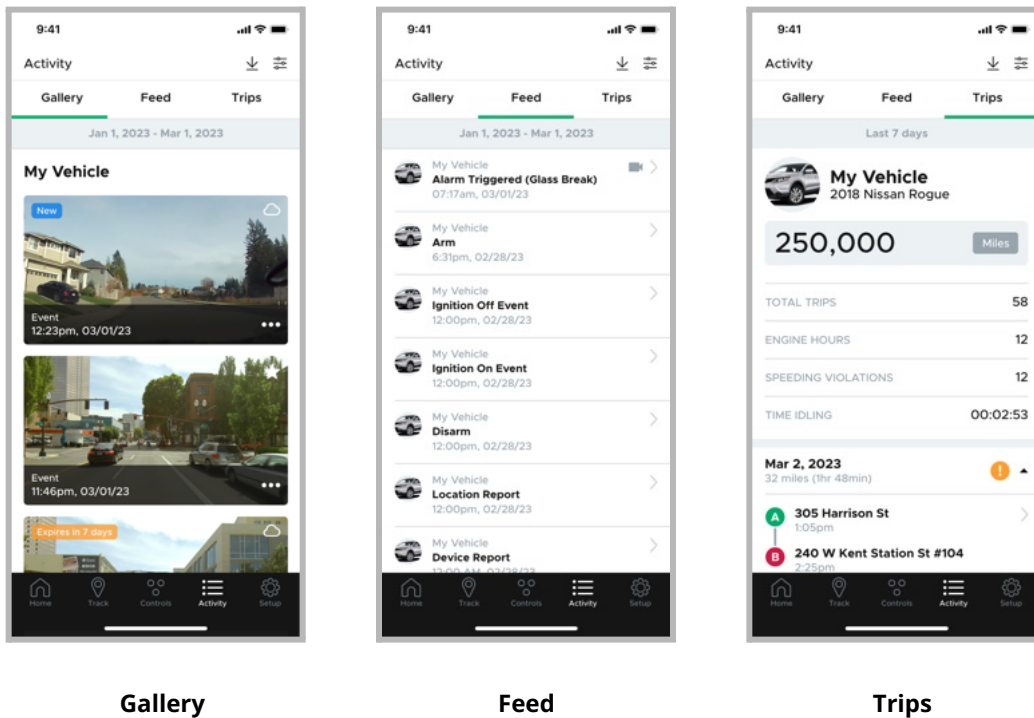

- **Gallery** - On the “Gallery” tab you can view, favorite, download, share, and delete media from your dash cam.
- **Feed** - The “Feed” tab lists all events and alerts regarding your vehicle(s). You can tap on each event to see more details. Events that include video recording(s) are marked with a “Video” icon
- **Trips** - The “Trips” tab records every drive you take in your vehicle(s). “Premium Plus” plans or higher have access to detailed trip reporting via breadcrumbing, turn-by-turn updates and location-based alerts. **(Please note: This feature only works when the Drone XC detects ignition on and off.)**

5.5 | Setup

The “Setup” page allows you to configure all settings associated with your DroneMobile account, hardware and app.

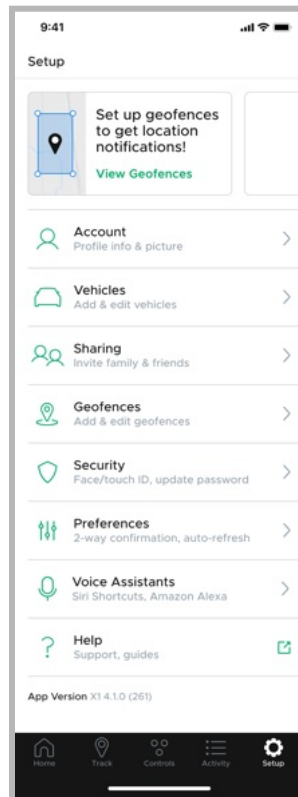

6 | Recording Modes

6.1 | Driving Mode

- Records video while your vehicle is in motion and the ignition is on.
- Records a separate 1-minute video clip anytime shock/impact is detected.
- You can adjust the sensitivity of Drone XC to events while driving from 1-5.

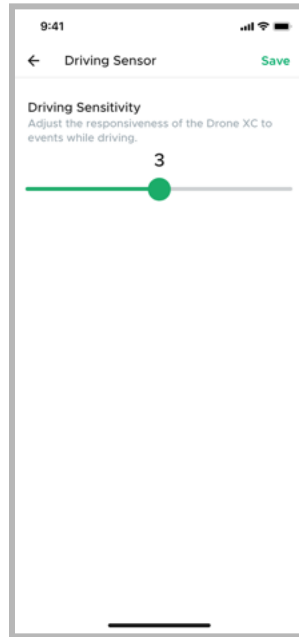

6.2 | Parking Mode

- When triggered, records 1-minute video clips while your vehicle is parked and the ignition is off.
- You can set what triggers video recordings during Parking Mode:
 - **Event** - Captures anything that would trigger the alarm (ex. shock/impact, glassbreak tilting/towing, etc.)
 - **Motion*** - Captures any movement within your camera's field of view.
 - **Event & Motion*** - Captures before and after an event is triggered
 - **Timelapse & Event*** - Continuously records video clips as well as when the alarm is triggered.

***This option requires more power and can deplete your battery in 1-2 days if your vehicle is not driven. We only recommend this option if you drive your vehicle daily.**

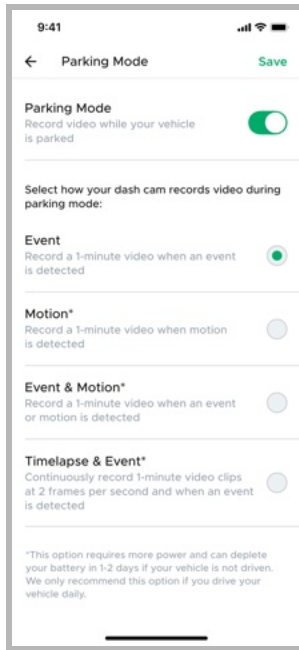

- You can adjust the sensitivity of Drone XC to events while parked from 1-5.

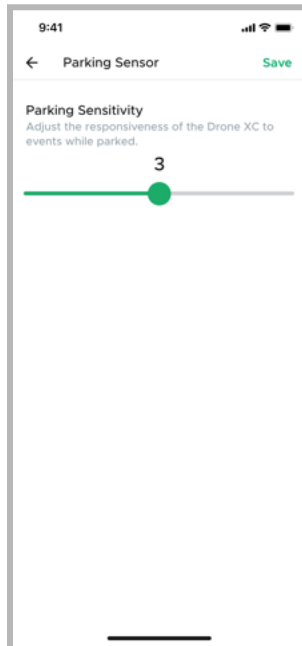

6.3 | Manual

- You can initiate a 1-minute manual recording by pressing the “record” button on the Drone XC dash cam.

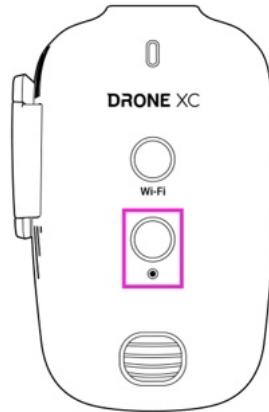

7 | Live View

Drone XC allows you to view a live video feed of what's happening at your vehicle. You have the option of live streaming remotely via LTE or while connected to your dash cam's Wi-Fi inside your vehicle.

7.1 | "Live View" via LTE (Requires a "Streaming" plan)

1. Navigate to the "Dash Cam" widget on the "Home" page.
2. Set "LTE" as your "Connection" type
3. Tap on the thumbnail to open the "Live View" window and wait 10-15 seconds for the live stream to start.

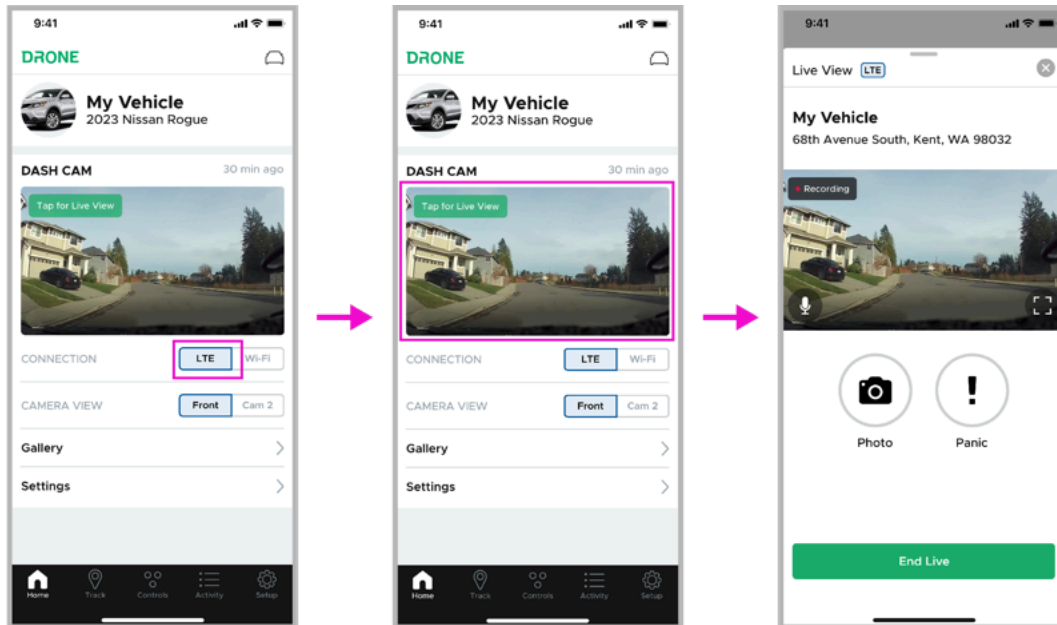

4. If "Live View" fails due to a technical error on our end, please tap "Retry". If this problem persists, tap on the "Still Need Help?" link for further assistance.

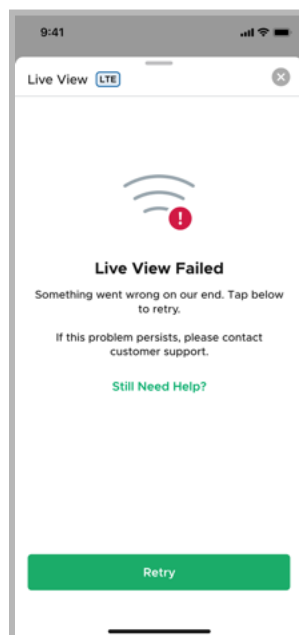

5. If “Live View” fails due to insufficient data, you can renew your “Streaming” plan early, or wait until your data is reset in the next billing cycle.

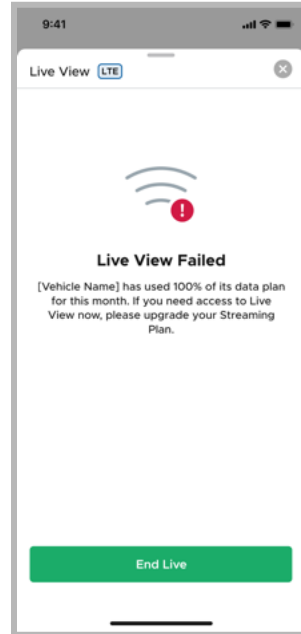

7.2 | “Live View” via Wi-Fi

1. Make sure you are inside your vehicle as the dash cam’s Wi-Fi has limited range.

(Please note: Your phone may have limited access to the internet while connected to the dash cam’s Wi-Fi.)

2. Navigate to the “Dash Cam” widget on the “Home” page.
3. Set “Wi-Fi” as your “Connection” type
4. Tap on the thumbnail to open the “Live View” window.

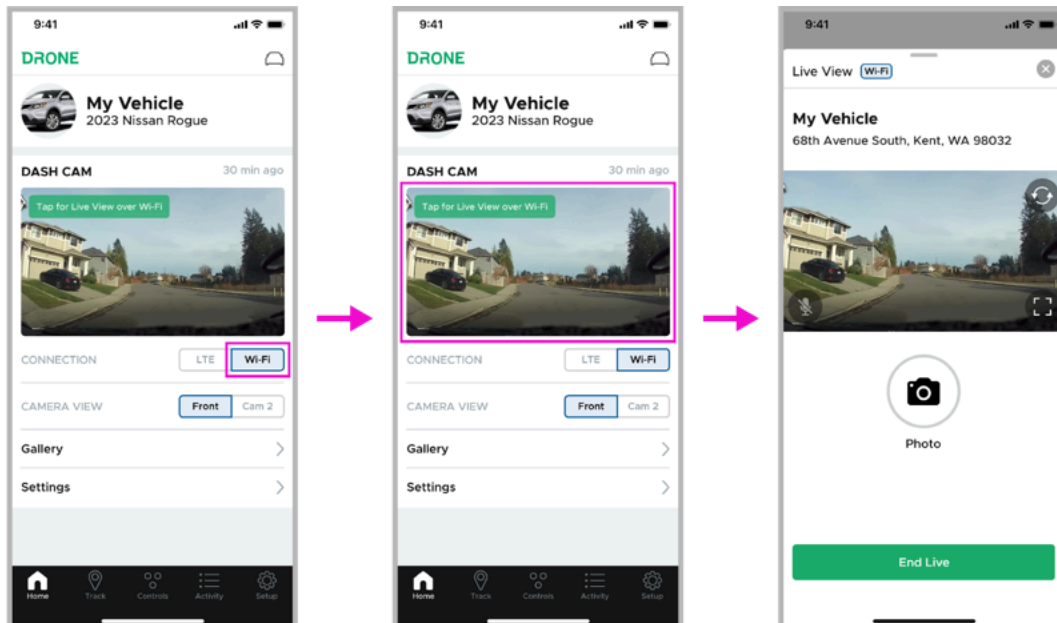

5. Follow the onscreen prompts to turn on your camera's Wi-Fi and connect.

(Please note: If you have a streaming plan, you will not need to physically press the dash cam's Wi-Fi button.)

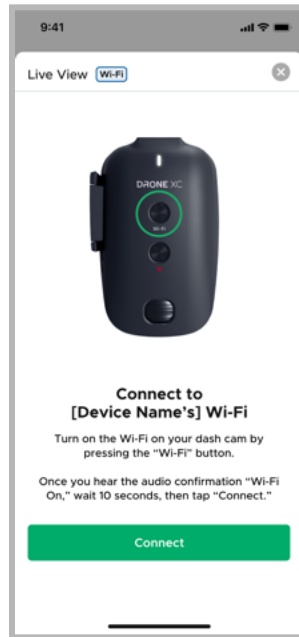

6. If "Live View" fails please try the following:

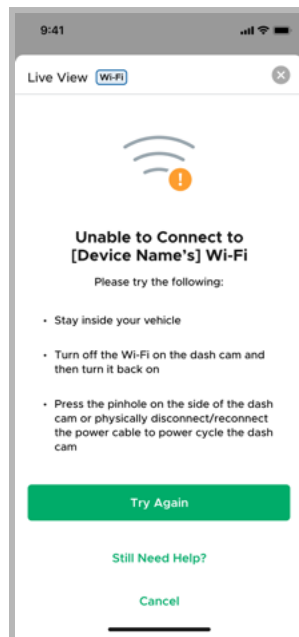

- Please make sure you stay inside your vehicle.
- Turn the Wi-Fi on your dash cam OFF and then ON
- Power cycle your dash cam by pressing the button inside the pinhole on the side of your dash cam OR by disconnecting & reconnecting the power cable.
- If the problem persists, tap on the "Still Need Help?" link for further assistance.

(Please note: Other Wi-Fi based products like “Wireless CarPlay” or “Wireless Android Auto” can significantly impact Wi-Fi performance of the dash cam. If you are having issues connecting, or staying connected to the dash cam’s Wi-Fi, please connect while the ignition is off.)

7.3 | “Live View” Controls

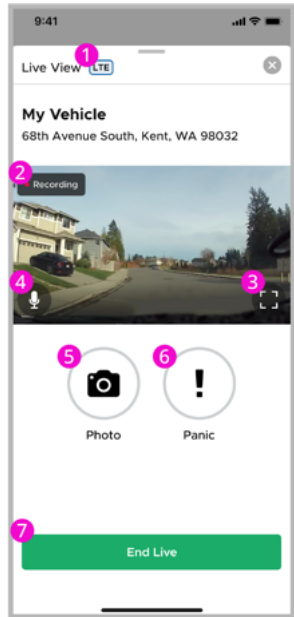

Live View



Live View (Full Screen)

1. **Connection Indicator** - Displays whether “Live View” is being accessed via Wi-Fi or LTE
2. **Recording Indicator** - LTE streams are recorded and saved to the cloud for 7 days unless favorited.
3. **Full Screen** - Rotates video between portrait and landscape view
4. **Mute** - Turns the microphone ON/OFF
5. **Snapshot** - takes a photo during “Live Stream” and saves it to your “Gallery”
6. **Panic** - LTE streams give you the ability to remotely trigger your vehicle’s alarm system
7. **End Live** - Close the “Live View” window by tapping the “End Live” button. You can also tap the “X” in the top right, or swipe down on the window itself to end a “Live View” session.

(Please note: Minimizing the app or closing the “Live View” window will terminate the live view session. If you start a new “Live View” session, you may have to wait 15-30 seconds.)

7.4 Live View from Secondary Camera

If you have a secondary camera (rear/interior) installed with your Drone XC, you can live view from your secondary camera as well.

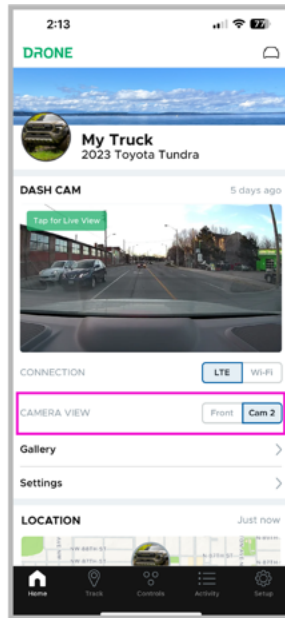

1. Navigate to the “Dash Cam” widget on your “Home” page.
2. Set “LTE” or “Wi-Fi” as your connection type.
3. Before tapping on the thumbnail and starting the live view session, select “Cam 2” from the “Camera View” options. This must be pressed before you start the Live View session.
4. Tap the thumbnail to start your Live View session.

SECONDARY CAMERA TROUBLESHOOTING

If your DroneMobile App does not show an option for a secondary camera, your system may not yet detect that you have a secondary camera installed. To troubleshoot this issue, please try the following:



1. Confirm that the connection from the secondary camera to the Drone XC 2.5mm input is secured.

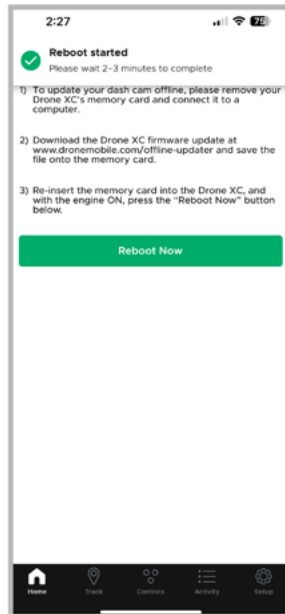

2. Try rebooting your Drone XC system. You can do this from the App* or by power cycling your Drone XC camera.
3. Power cycle your dash cam by pressing the button inside the pinhole on the side of your dash cam OR by disconnecting & reconnecting the power cable.
4. Force close your DroneMobile App and/or log out from your DroneMobile App and log back in again.

*- Reboot your Drone XC Camera from the DroneMobile App by going to Dash Cam settings > “Update Dash Cam” > “Update Now”. Streaming plan required. If you do not have a Streaming Plan, please press the reboot pin on the actual camera to power cycle it.

8 | Gallery

The Drone XC's Gallery is accessible on the "Activity" page as well as the "Dash Cam" widget on the "Home" page.

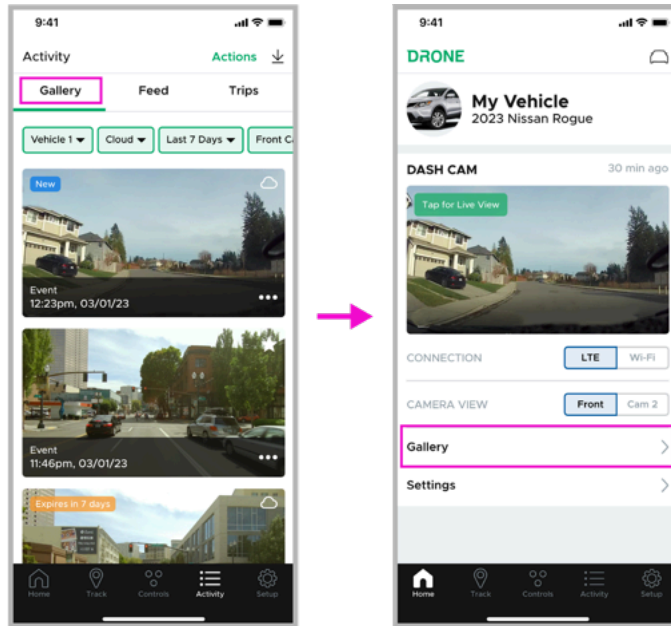

You can view media stored on the cloud or your dash cam's SD card by selecting your source in the quick filter bar. (To learn more about the "Quick Filter Bar" see section [8.4 - "Quick Filter Bar"](#).)



Cloud

Events (if enabled) and live streams captured on your dash cam are automatically backed up to the cloud via LTE.



Camera SD Card

Local storage on your dash cam. (You must be near your camera's Wi-Fi to access)

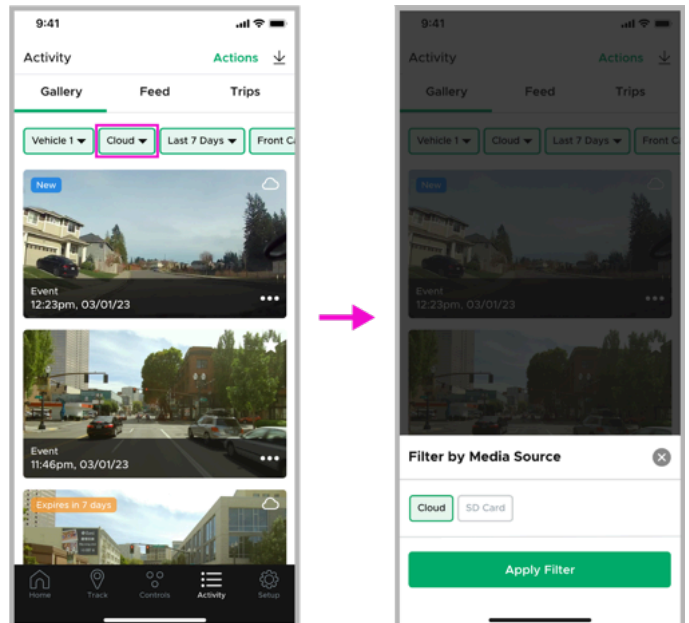

8.1 | Cloud Gallery

The “Cloud” gallery displays a log of media from your Drone XC dash cam that is stored in the cloud. Live streams are stored on the cloud, but expire in 7 days unless they are favorited. If you have the “Auto-Upload” feature turned on under your Drone XC’s “Storage” settings, recordings triggered by alarm events will also be auto-uploaded to the Cloud gallery. All of your other recordings will be visible in the “SD Card” gallery.

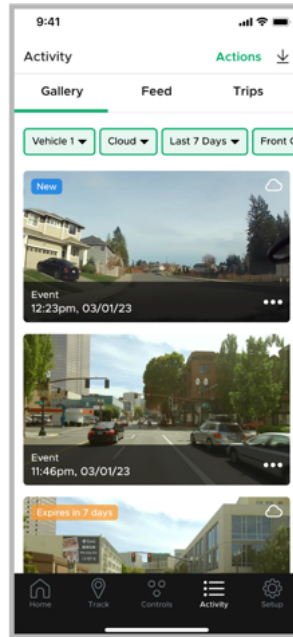

(Please note: A “Streaming” plan is required in order to have access to the “Cloud” gallery. To learn more about “Streaming” plans see section [4.3 - “Selecting Your DroneMobile Plan”](#).)

The “Cloud” gallery consists of a timeline of media thumbnails. Within each thumbnail you will find the event name, time & date, source/star indicator in the top right, and space in the top left corner for a badge indicating the status of the media item. Additionally you will see a “More Actions” icon in the bottom right.

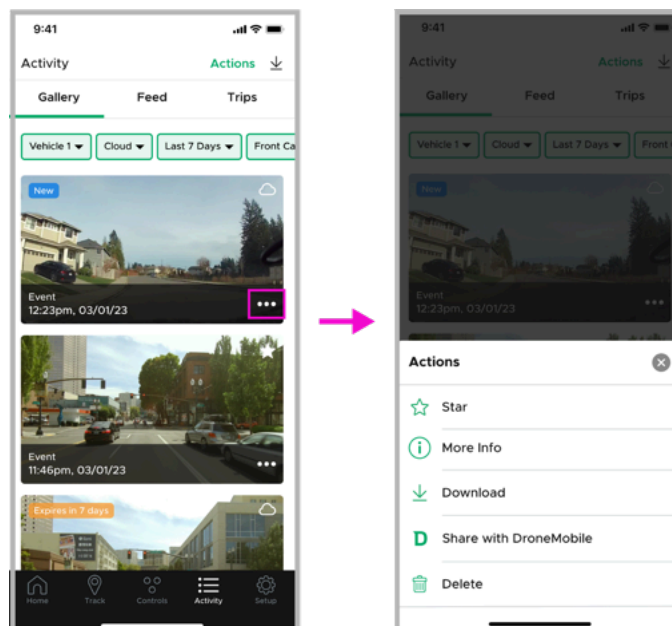

The “More Actions” pop-up gives you the ability to star/favorite, get more info, download, share with DroneMobile, or delete. In order to download media, you will need to give the DroneMobile App permission to access your photo library.

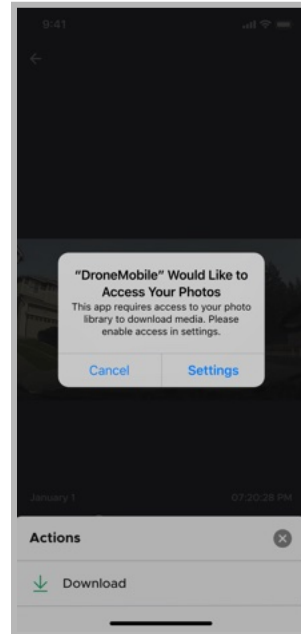

The “Cloud” gallery media thumbnails show the front camera view by default. If you would like to view media from the rear or interior camera (if installed) you can change the camera view on the quick filter bar. (To learn more about the “Quick Filter Bar” see section [8.4 - “Quick Filter Bar”](#).)

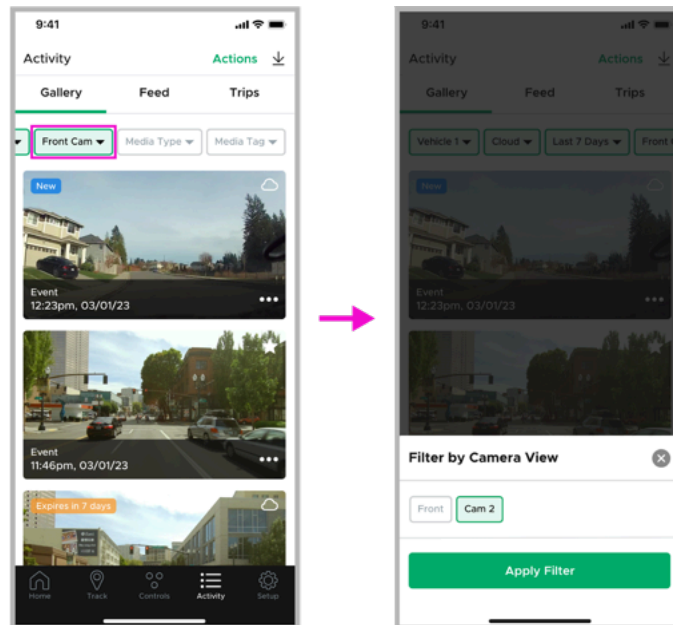

8.2 | SD Card Gallery

(Please note: You must be in your vehicle and connected to your dash cam's Wi-Fi in order to view the "SD Card" gallery. Other Wi-Fi based products like "Wireless CarPlay" or "Wireless Android Auto" can significantly impact Wi-Fi performance of the dash cam. If you are having issues connecting, or staying connected to the dash cam's Wi-Fi, please connect while the ignition is off.)

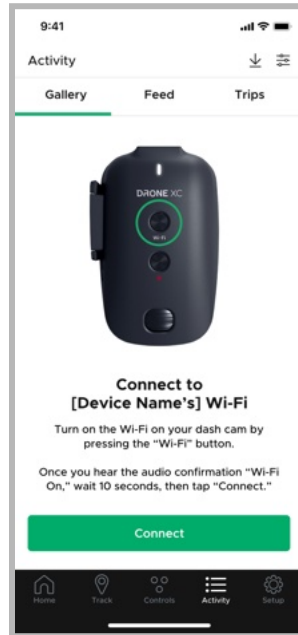

The "SD Card" gallery displays a log of media from your Drone XC dash cam that is stored on the SD Card. All drives, parking mode timelapses (if enabled), snapshots, and driving/parking events are stored on the SD Card.

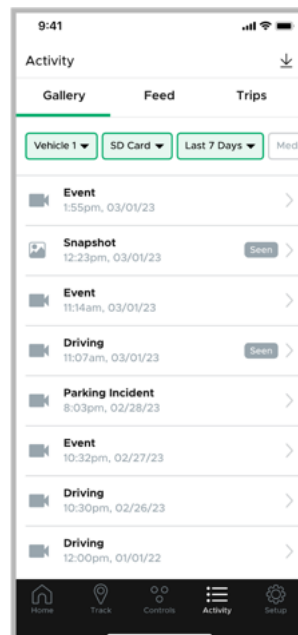

The "SD Card" gallery is a timeline list of media items. Within each item you will find an icon indicator of the media type, the event name, and time & date. Each item can be tapped to access the "Media Player/Viewer" page. Each item that you have tapped will be marked with a "Seen" badge, to help you keep track of which items you've already interacted with.

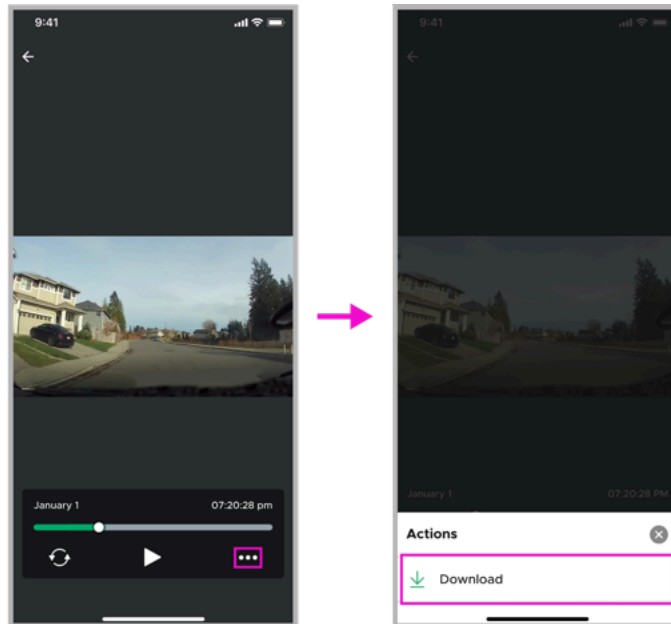

On this page you will find the "More Actions" icon which gives you the ability to download. In order to download media, you will need to give the DroneMobile App permission to access your photo library.

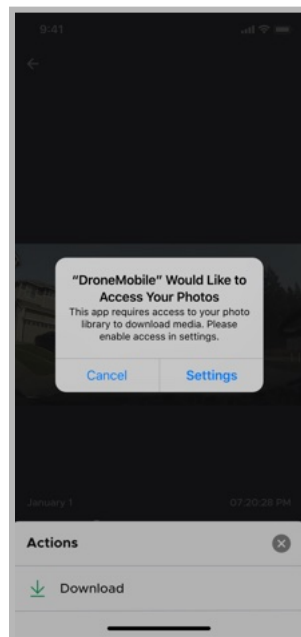

8.3 | Media Download Queue

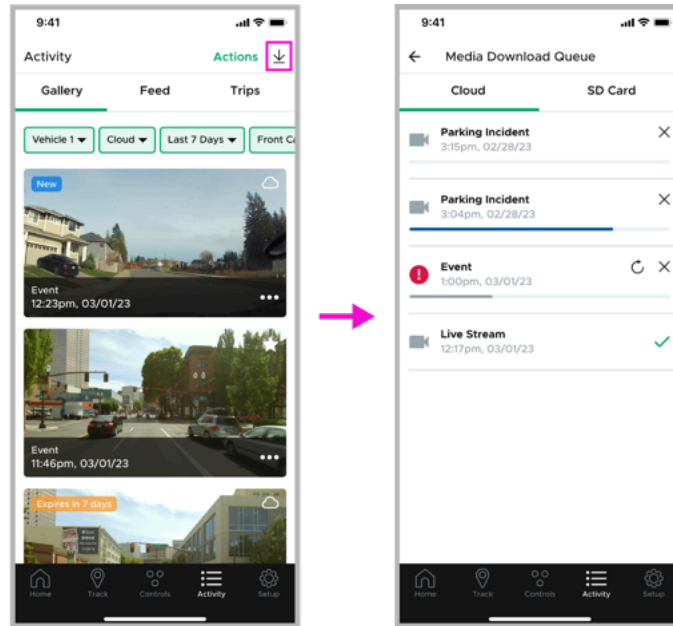

The “Media Download Queue” shows the progress of items currently being downloaded to your device. You can access this page by tapping on the “Download” icon in the top right corner of the “Activity” page. On this page, queued items are separated into “Cloud” and “SD Card” tabs. For each item in the queue you will see an icon indicator of the media type, event name, date & time, and progress bar. You may also see an “X” icon to cancel in-progress downloads, a “Retry” icon for failed downloads, or a green checkmark for completed downloads.

(Please note: If you are downloading from the SD card via Wi-Fi, you must remain in the vehicle until the download is complete, otherwise, it will fail.)

8.4 | Quick Filter Bar

The quick filter bar is a side-scrolling series of dropdowns that allows you to refine the media items you are viewing. This bar will be pinned to the top of the “Gallery” page for easy access.



Any active filters will be highlighted in Green. The filter options on the quick filter bar are:

- **Vehicle** - Select which vehicle's media you would like to view
- **Source** - Cloud or SD Card (If you have a streaming plan, "Cloud" will be your default source)
- **Date Range** - Last 7 Days, Last 30 Days, Custom Date Range
- **Camera View** - Front, Rear/Interior (Only available on the Cloud gallery if a secondary camera is installed)
- **Media Type** - Events, Live Stream, Parking Incidents, Snapshots
- **Media Tag** - Expiring Soon, Starred (Only available on Cloud gallery view)

9 | Downloading Media

9.1 | Downloading Media via LTE on the “Gallery”

(Please note: This feature is for customers with “Streaming” plans only.)

1. Navigate to the “Gallery” tab on the “Activity” page. Select “Cloud” as your source.

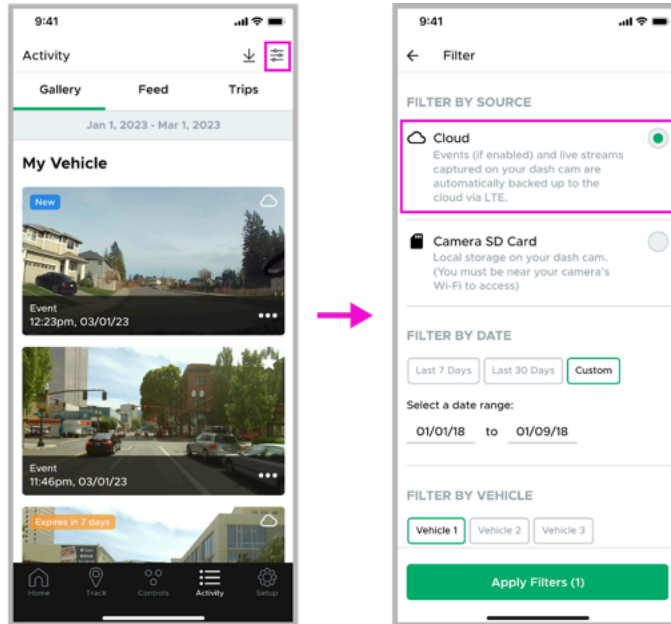

2. Tap the “More Actions” icon on the thumbnail of the media you would like to download. You can also tap the “More Actions” icon on the “Media Player/Viewer” page. Next, tap “Download” on the “More Actions” pop-up.

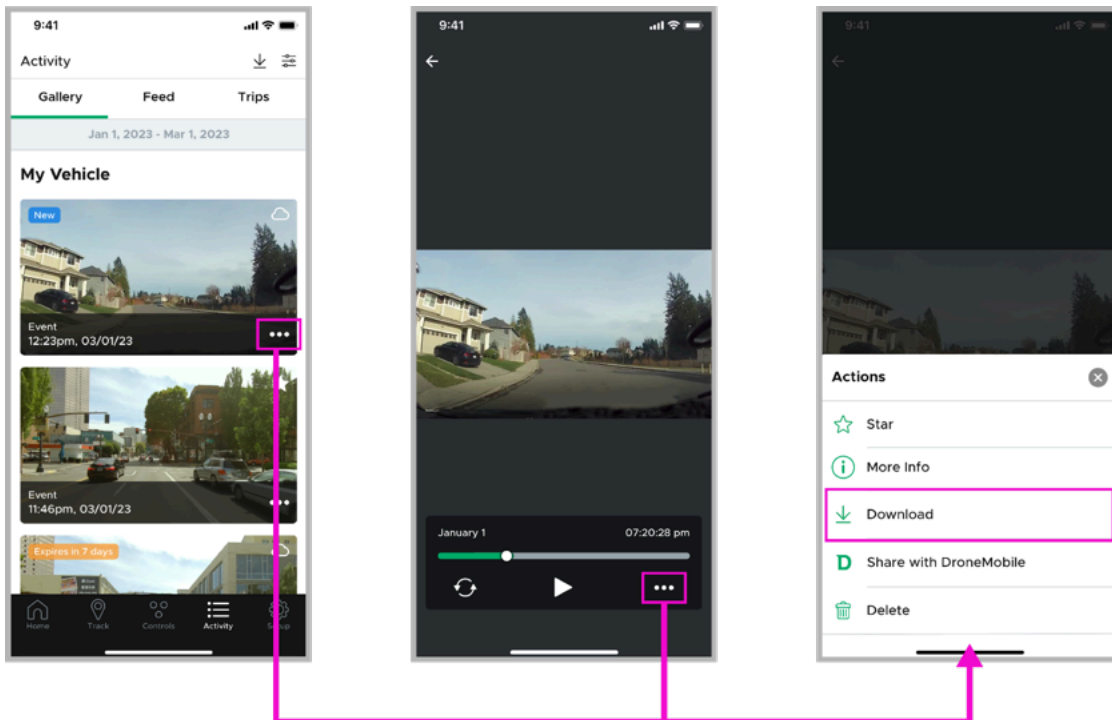

(Please note: In order to download media, you will need to give the DroneMobile App permission to access your photo library.)

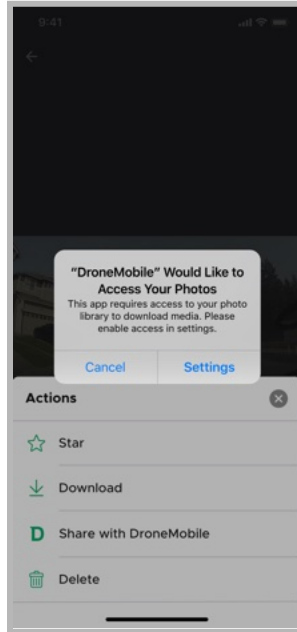

3. The item will be added to the "Media Download Queue" under the "Cloud" tab.
4. You will be notified when the item has been saved to your device's photo library.

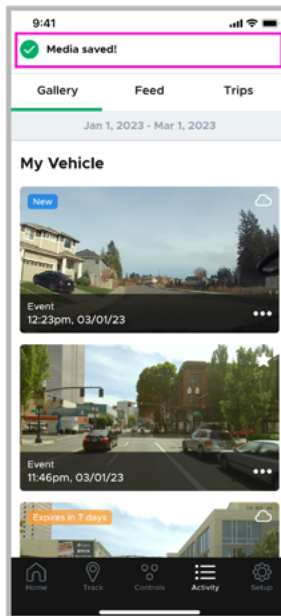

9.2 | Downloading Media via LTE on the “Feed”

(Please note: This feature is for customers with “Streaming” plans only.)

1. Navigate to the “Feed” tab on the “Activity” page. On the “Feed,” only alarm events will have video. Tap on the alarm event with the media you would like to download. This will take you to the “Event Details” page.



2. On the “Event Details” page you will see a thumbnail for the media associated with that event. Tap the thumbnail to open the “Media Player” page. From there you can tap on the “More Actions” icon, and tap “Download” on the pop-up that appears.

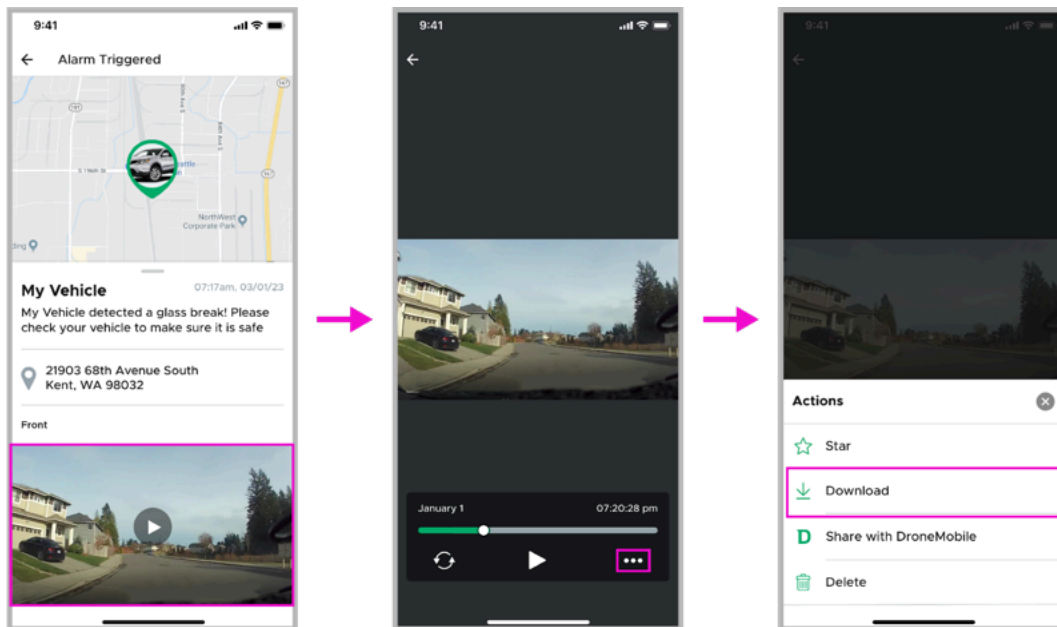

(Please note: If the media for that event has not yet been uploaded to the cloud, you can tap the thumbnail to request the media over LTE. Alternatively, you can locate and download the media from your SD Card.)

9.3 | Downloading Media via Wi-Fi on the “Gallery”

(Please note: You must be in your vehicle and connected to your dash cam’s Wi-Fi in order to download media from your SD Card.)

1. Navigate to the “Gallery” tab on the “Activity” page. Select “SD Card” as your source.

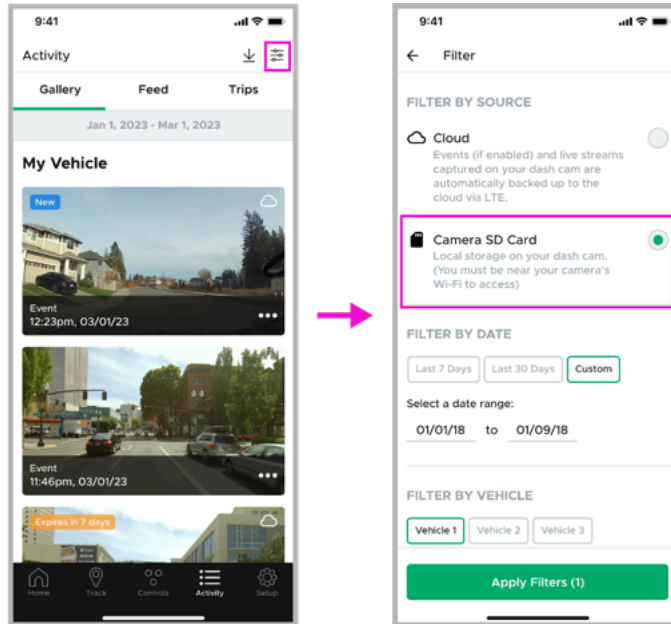

2. Follow the onscreen prompts to connect to the dash cam’s Wi-Fi.



- Next, tap on the item you would like to download. The “Media Player/Viewer” page will open. From there you can tap on the “More Actions” icon, and tap “Download” on the pop-up that appears.

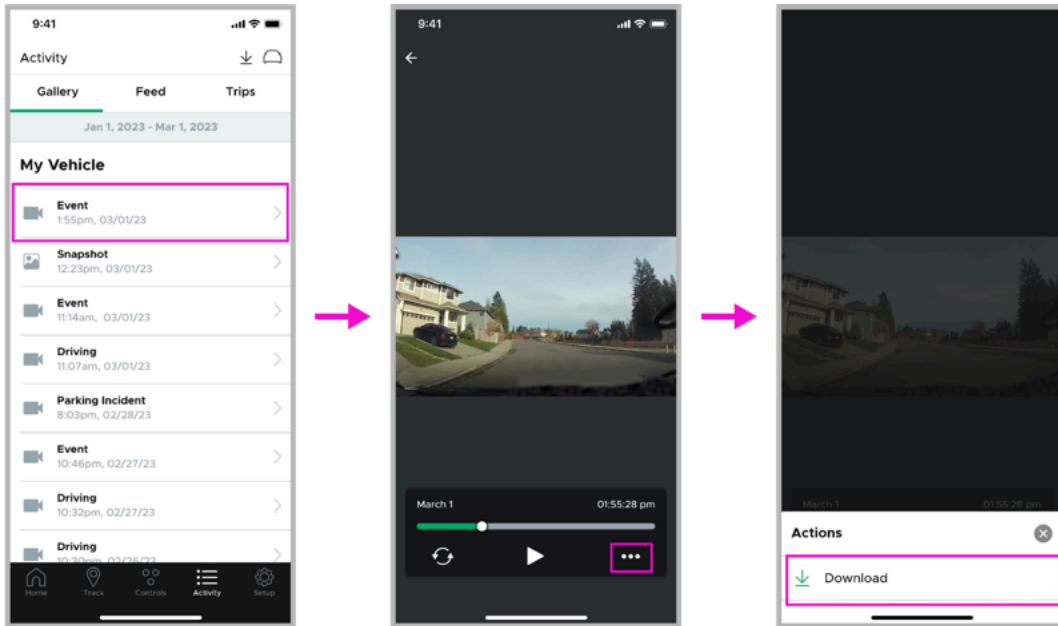

(Please note: In order to download media, you will need to give the DroneMobile App permission to access your photo library.)

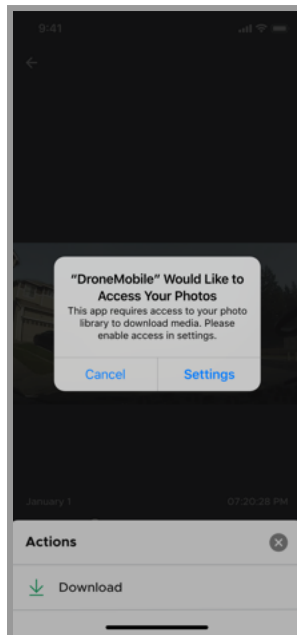

4. You will be notified when the item has been saved to your device's photo library.

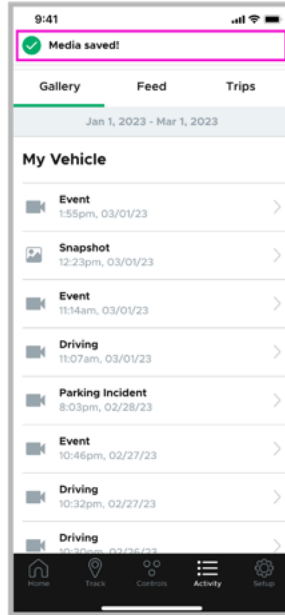

(Please note: If you are downloading from the SD card via Wi-Fi, you must remain in the vehicle until the download is complete, otherwise, it will fail.)

9.4 | Downloading Media via Micro-SD Card

1. The Micro-SD card is located on the side of the Drone XC dash cam, underneath the security cover.

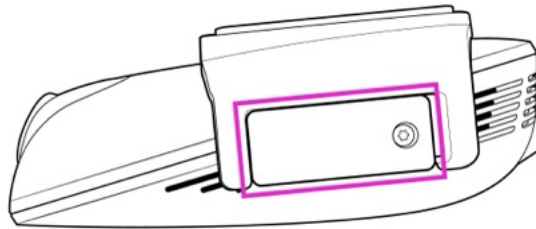

2. Remove the security screw and the cover using the provided screwdriver.

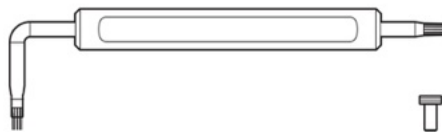

3. Push the Micro-SD card in to eject the card from the camera.

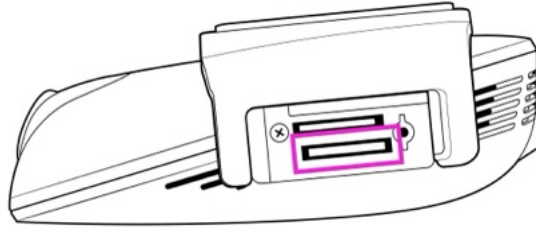

4. Insert the Micro-SD card into any compatible computer to download your media. (Micro-SD card adapter not included)

(Please note: Micro-SD card adapter not included)

10 | Warranty

Drone XC is covered by a 1-Year Manufacturer's Warranty to protect your purchase from malfunctioning or defective hardware. The warranty term starts from the day that the device is installed by an authorized dealer. Installations performed at a non-authorized retailer will not be covered under warranty.

To file a warranty claim, visit <https://help.dronemobile.com> to contact our support team. Please make sure that your Drone XC is registered to your email address so that we can verify your ownership.

These warranties are non-transferrable and belong solely to the original purchaser of the unit. These warranties will expire if the original purchaser ever sells the vehicle, in which the DroneMobile system is installed.

For DroneMobile's full warranty terms, please visit www.dronemobile.com/warranty.

For all other terms, conditions, and policies, please visit www.dronemobile.com/legal.

11 | Troubleshooting

11.1 | Wi-Fi Issues

The Wi-Fi connection from my smartphone to Drone XC ends after iOS prompts me to use cellular.

When prompted to use cellular, press the “Stay on Wi-Fi” button. If you switch to cellular, the Wi-Fi connection to your Drone XC will end.

I can't connect to Drone XC's Wi-Fi because of wireless CarPlay/Android Auto.

Connect while the engine is off. Most smartphones “prefer” CarPlay/Android Auto over other 3rd party devices, and there is no way to override this while the engine is on.

11.2 | Gallery/Media Issues

I can't download Drone XC videos to my phone.

In order to download media, you will need to give the DroneMobile App permission to access your photo library. You can do so by tapping “Allow” when prompted in the DroneMobile App or by visiting your smartphone settings.

For detailed instructions on how to download media, please reference [9 | Downloading Media](#).

Why don't I see my videos in the gallery?

Make sure you have the correct filter selected. The “Cloud” filter will display events (if enabled) and live streams captured on your dash cam. This requires a “Streaming” plan. Please note, some media will not be visible in the gallery until it has uploaded to the cloud. You will receive a notification once new media becomes available in the cloud.

The “SD Card” filter will display all drives, parking mode timelapses (if enabled), snapshots, and driving/parking events. In order to view “SD Card” media, you will need to connect to your Drone XC's Wi-Fi.

11.3 | Miscellaneous Issues

Where is my serial number?

At the time of installation, your authorized DroneMobile installer should have provided you with a few materials where you can locate your DroneMobile system's serial number)

- **Keychain Tag** - DroneMobile systems come with a keychain tag that your DroneMobile installer should have attached to your keychain or remote fob. This keychain tag has your system's serial number and barcode, which you can easily scan from the DroneMobile app.
- **Door Jamb Sticker** - As a backup, your DroneMobile installer may also place a sticker with your system's serial number to the driver's side door jamb, which is the area that connects your door to the vehicle body.
- **On the Drone XC Dash Cam itself** - All Drone XC Dash Cams have a label with your system's serial number. Remove the dash cam from the mounting bracket to access the label.
- **Bill of Sale** - As a last resort, check your bill of sale from your DroneMobile retailer, as your serial number may have been included on that document as well.

11.4 | Secondary Camera Not Displaying

If your DroneMobile App does not show an option for a secondary camera, your system may not yet detect that you have a secondary camera installed. To troubleshoot this issue, please try the following:



1. Confirm that the connection from the secondary camera to the Drone XC 2.5mm input is secured.

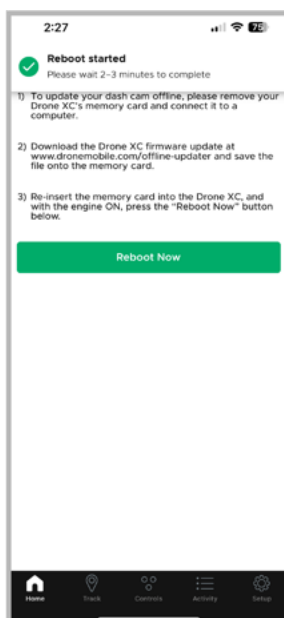

2. Try rebooting your Drone XC system. You can do this from the App* or by power cycling your Drone XC camera.
 - a. Power cycle your dash cam by pressing the button inside the pinhole on the side of your dash cam OR by disconnecting & reconnecting the power cable.
3. Force close your DroneMobile App and/or log out from your DroneMobile App and log back in again.

*- Reboot your Drone XC Camera from the DroneMobile App by going to Dash Cam settings > "Update Dash Cam" > "Update Now". Streaming plan required. If you do not have a Streaming Plan, please press the reboot pin on the actual camera to power cycle it.

12 | Contact

Help: <https://help.dronemobile.com>

Login: <https://accounts.dronemobile.com>

Find a Dealer: <https://www.dronemobile.com/find-a-dealer>

Facebook/IG/Youtube: @dronemobile