



HOW TO USE THIS INSTALL GUIDE

- 1** Open the Bookmarks menu and find your vehicle OR scroll down until you find the install guide for your vehicle.
- 2** Print only the pages for your vehicle using the advanced options in the Print menu.
- 3** Install your Maestro RR according to the guide for your vehicle.

WARNING

Pressing the printer icon or “quick printing” this document will print all of the guides in this compilation.



INSTALL GUIDE SUBARU CROSSTREK WITHOUT NAV 2013-2014

RETAINS STEERING WHEEL CONTROLS, AMPLIFIER AND MORE!



PRODUCTS REQUIRED

iDataLink Maestro RR Radio Replacement Interface
iDataLink Maestro SU1 Installation Harness

PROGRAMMED FIRMWARE

ADS-RR(SR)-SUB02A-DS

OPTIONAL ACCESSORIES



ACC-uSU1

Click here for:

[Radar Integration Installation Guide](#)

[Radar Integration Owner's Guide for Kenwood and JVC Radios](#)

WELCOME

Congratulations on the purchase of your iDatalink Maestro RR Radio replacement solution. You are now a few simple steps away from enjoying your new car radio with enhanced features.

Before starting your installation, please ensure that your iDatalink Maestro module is programmed with the correct firmware and that you carefully review the Installation Diagram and Vehicle Wire Reference Chart.

Please note that Maestro RR will only retain functionalities that were originally available in the vehicle.

NEED HELP?

 **1 866 427-2999**

 maestro.support@adsdata.ca

 maestro.idatalink.com/support
www.12voltdata.com/forum

TABLE OF CONTENTS

Installation Instructions	3
Wiring Diagram	4
Radio Wire Reference Chart	5

INSTALLATION INSTRUCTIONS

STEP 1

- Unbox the aftermarket radio and locate its main harness.
- Cut the WHITE, GRAY, GREEN and PURPLE RCA tips.
- Connect the wires from aftermarket radio main harness to the SU1 T-harness and match the wire functions.
- Remove the factory radio.

STEP 2

- Assemble the SU1 T-harness and connect it to the factory radio harness.

STEP 3

- Plug the OBDII connector into the OBDII of the vehicle, under driver dash.

STEP 4

- Plug the aftermarket radio harnesses into the aftermarket radio.
- Plug the Data cable to the data port of the aftermarket radio.
- Insert the Audio cable into the iDataLink 3.5 mm audio jack of the aftermarket radio.

STEP 5

- Connect all the harnesses to the Maestro RR module then test your installation.

TROUBLESHOOTING TIPS:

- To reset the module back its factory settings, turn the key to the OFF position then disconnect all connectors from the module. Press and hold the module's programming button and connect all the connectors back to the module. Wait, the module's LED will flash RED rapidly (this may take up to 10 seconds). Release the programming button. Wait, the LED will turn solid GREEN for 2 seconds.
- For technical assistance call 1-866-427-2999 or e-mail "maestro.support@idatalink.com". Visit us at "maestro.idatalink.com/support" and "www.12voldata.com/forum/"

WIRING DIAGRAM

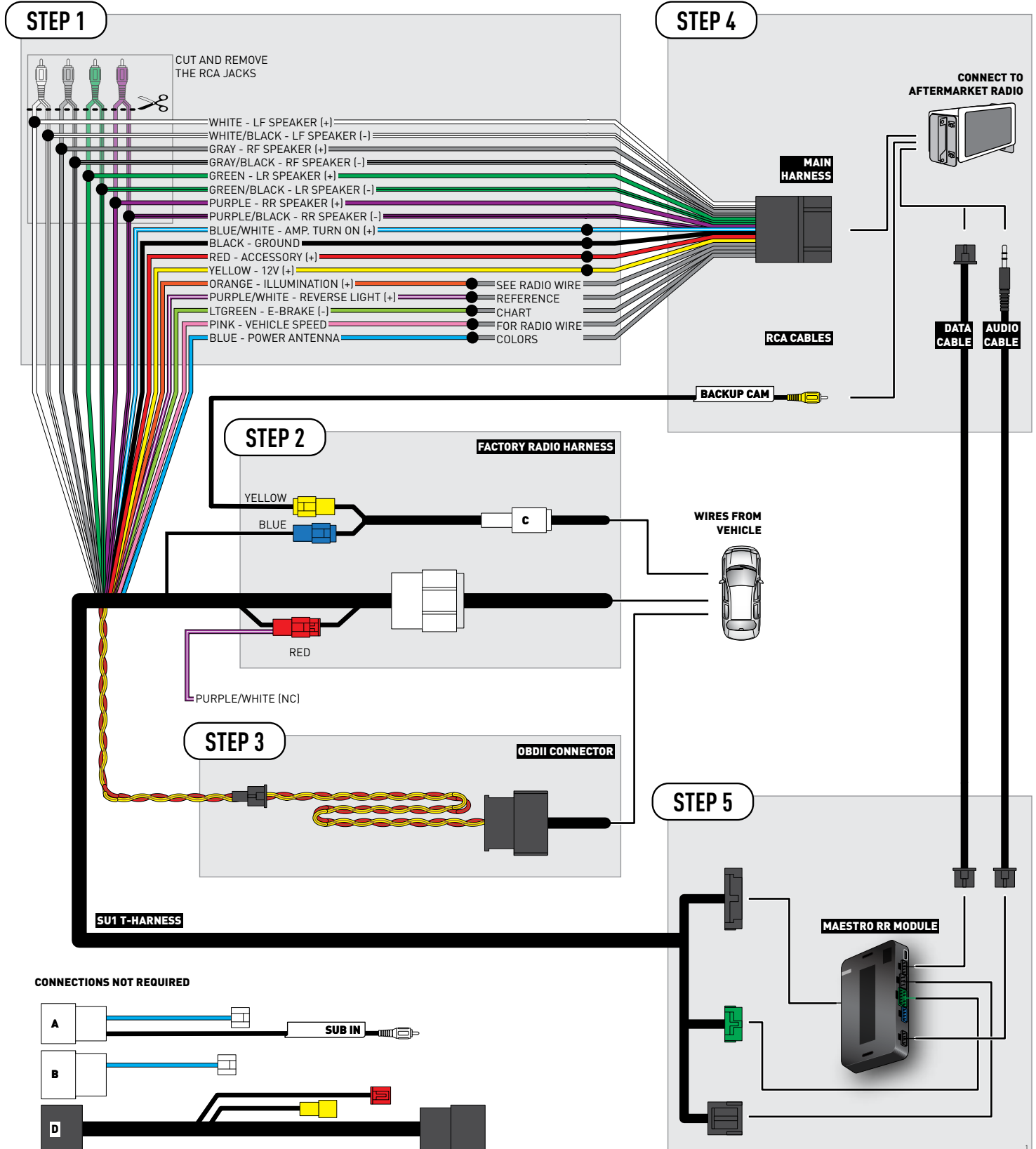

RADIO WIRE REFERENCE CHART

Wire Description	Polarity	Wire Color on Maestro T-Harness	Wire Color on Alpine cable	Wire Color on Kenwood cable	Wire Color on Pioneer cable
Illumination	(+)	Orange	N/A	Orange/White	Orange/White
Reverse Light	(+)	Purple/White	Orange/White	Purple/White	Purple/White
E-Brake	(-)	Lt Green	Yellow/Blue	Lt Green	Lt Green
VSS (vehicle speed sensor)	(DATA)	Pink	Green/White	N/A	Pink
Power Antenna	(+)	Blue	Blue	Blue	N/A



INSTALL GUIDE SUBARU FORESTER WITH HARMAN KARDON 2014-2015

RETAINS STEERING WHEEL CONTROLS, AMPLIFIER AND MORE!



PRODUCTS REQUIRED

iDataLink Maestro RR Radio Replacement Interface
iDataLink Maestro SU1 Installation Harness

PROGRAMMED FIRMWARE

ADS-RR(SR)-SUB02A-DS

OPTIONAL ACCESSORIES



ACC-uSU1

Click here for:

[Radar Integration Installation Guide](#)

[Radar Integration Owner's Guide for Kenwood and JVC Radios](#)

WELCOME

Congratulations on the purchase of your iDatalink Maestro RR Radio replacement solution. You are now a few simple steps away from enjoying your new car radio with enhanced features.

Before starting your installation, please ensure that your iDatalink Maestro module is programmed with the correct firmware and that you carefully review the Installation Diagram and Vehicle Wire Reference Chart.

Please note that Maestro RR will only retain functionalities that were originally available in the vehicle.

NEED HELP?

 **1 866 427-2999**

 maestro.support@adsdata.ca

 maestro.idatalink.com/support
www.12voltdata.com/forum

TABLE OF CONTENTS

Installation Instructions	3
Wiring Diagram	4
Radio Wire Reference Chart	5

INSTALLATION INSTRUCTIONS

STEP 1

- Unbox the aftermarket radio and locate its main harness.
- Connect the wires from aftermarket radio main harness to the SU1 T-harness and match the wire functions.
- Remove the factory radio.

STEP 2

- Assemble the SU1 T-harness and connect it to the factory radio harness.

STEP 3

- Plug the OBDII connector into the OBDII of the vehicle, under driver dash.

STEP 4

- Plug the aftermarket radio harnesses into the aftermarket radio.
- Plug the RCA cables to the aftermarket radio.
- Plug the Data cable to the data port of the aftermarket radio.
- Insert the Audio cable into the iDataLink 3.5 mm audio jack of the aftermarket radio.

STEP 5

- Connect all the harnesses to the Maestro RR module then test your installation.

TROUBLESHOOTING TIPS:

- To reset the module back its factory settings, turn the key to the OFF position then disconnect all connectors from the module. Press and hold the module's programming button and connect all the connectors back to the module. Wait, the module's LED will flash RED rapidly (this may take up to 10 seconds). Release the programming button. Wait, the LED will turn solid GREEN for 2 seconds.
- For technical assistance call 1-866-427-2999 or e-mail "maestro.support@idatalink.com". Visit us at "maestro.idatalink.com/support" and "www.12voldata.com/forum/"

WIRING DIAGRAM

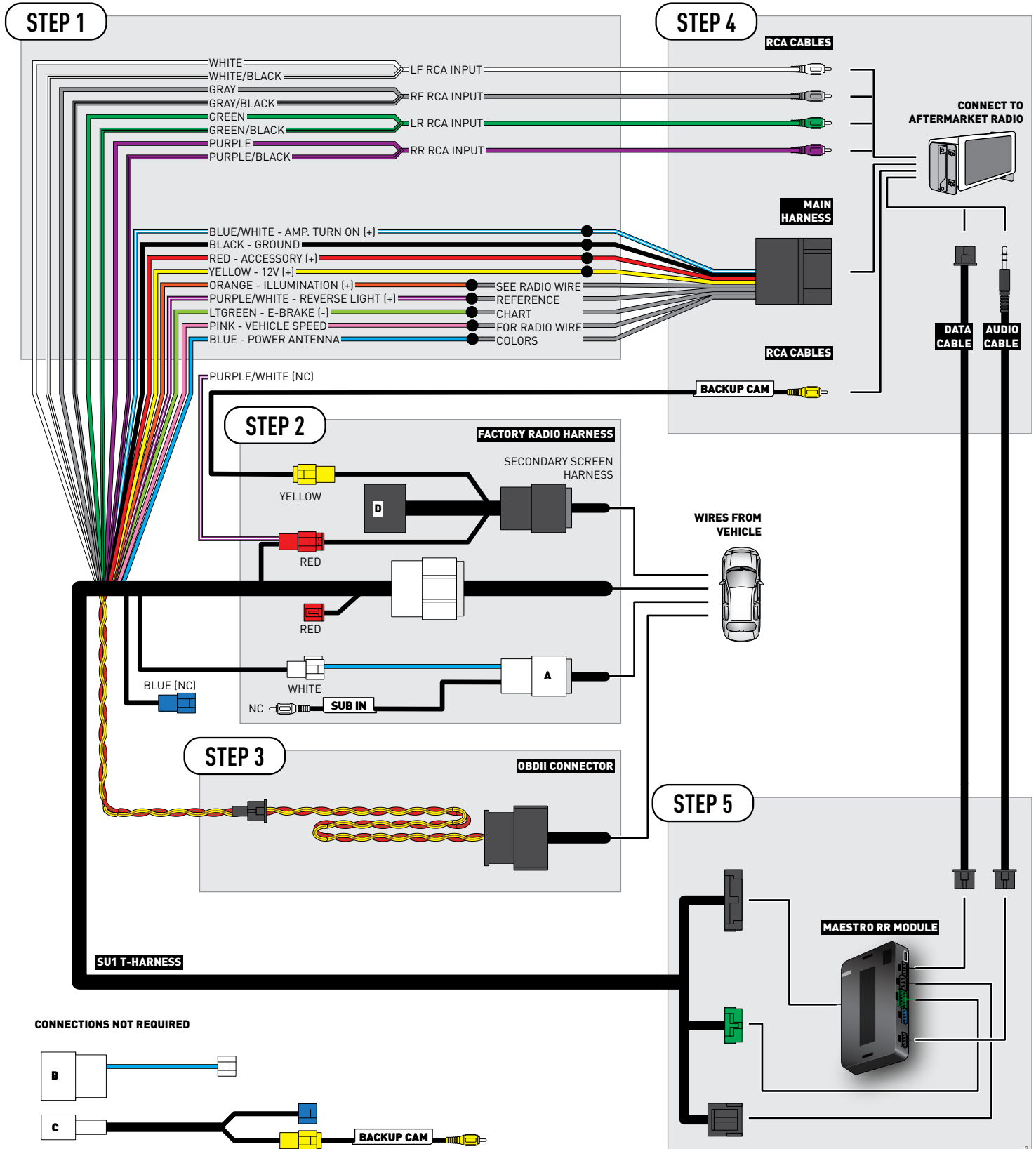

RADIO WIRE REFERENCE CHART

Wire Description	Polarity	Wire Color on Maestro T-Harness	Wire Color on Alpine cable	Wire Color on Kenwood cable	Wire Color on Pioneer cable
Illumination	(+)	Orange	N/A	Orange/White	Orange/White
Reverse Light	(+)	Purple/White	Orange/White	Purple/White	Purple/White
E-Brake	(-)	Lt Green	Yellow/Blue	Lt Green	Lt Green
VSS (vehicle speed sensor)	(DATA)	Pink	Green/White	N/A	Pink
Power Antenna	(+)	Blue	Blue	Blue	N/A



INSTALL GUIDE SUBARU FORESTER WITHOUT NAV 2014-2015

RETAINS STEERING WHEEL CONTROLS, AMPLIFIER AND MORE!



PRODUCTS REQUIRED

iDataLink Maestro RR Radio Replacement Interface
iDataLink Maestro SU1 Installation Harness

PROGRAMMED FIRMWARE

ADS-RR(SR)-SUB02A-DS

OPTIONAL ACCESSORIES



ACC-uSU1

Click here for:

[Radar Integration Installation Guide](#)

[Radar Integration Owner's Guide for Kenwood and JVC Radios](#)

WELCOME

Congratulations on the purchase of your iDatalink Maestro RR Radio replacement solution. You are now a few simple steps away from enjoying your new car radio with enhanced features.

Before starting your installation, please ensure that your iDatalink Maestro module is programmed with the correct firmware and that you carefully review the Installation Diagram and Vehicle Wire Reference Chart.

Please note that Maestro RR will only retain functionalities that were originally available in the vehicle.

NEED HELP?

 **1 866 427-2999**

 maestro.support@adsdata.ca

 maestro.idatalink.com/support
www.12voltdata.com/forum

TABLE OF CONTENTS

Installation Instructions	3
Wiring Diagram	4
Radio Wire Reference Chart	5

INSTALLATION INSTRUCTIONS

STEP 1

- Unbox the aftermarket radio and locate its main harness.
- Cut the WHITE, GRAY, GREEN and PURPLE RCA tips.
- Connect the wires from aftermarket radio main harness to the SU1 T-harness and match the wire functions.
- Remove the factory radio.

STEP 2

- Assemble the SU1 T-harness and connect it to the factory radio harness.

STEP 3

- Plug the OBDII connector into the OBDII of the vehicle, under driver dash.

STEP 4

- Plug the aftermarket radio harnesses into the aftermarket radio.
- Plug the Data cable to the data port of the aftermarket radio.
- Insert the Audio cable into the iDataLink 3.5 mm audio jack of the aftermarket radio.

STEP 5

- Connect all the harnesses to the Maestro RR module then test your installation.

TROUBLESHOOTING TIPS:

- To reset the module back its factory settings, turn the key to the OFF position then disconnect all connectors from the module. Press and hold the module's programming button and connect all the connectors back to the module. Wait, the module's LED will flash RED rapidly (this may take up to 10 seconds). Release the programming button. Wait, the LED will turn solid GREEN for 2 seconds.
- For technical assistance call 1-866-427-2999 or e-mail "maestro.support@idatalink.com". Visit us at "maestro.idatalink.com/support" and "www.12voldata.com/forum/"

WIRING DIAGRAM

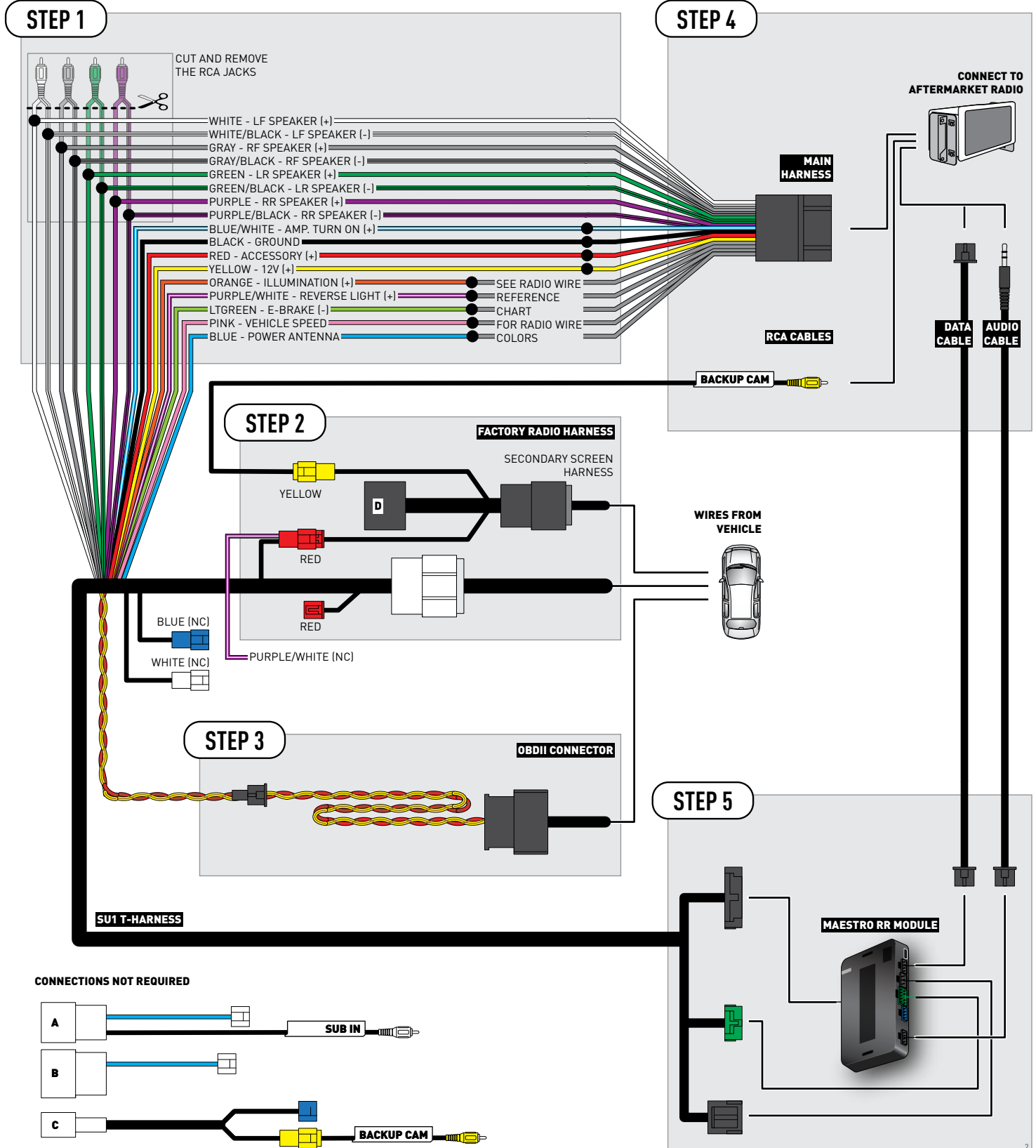

RADIO WIRE REFERENCE CHART

Wire Description	Polarity	Wire Color on Maestro T-Harness	Wire Color on Alpine cable	Wire Color on Kenwood cable	Wire Color on Pioneer cable
Illumination	(+)	Orange	N/A	Orange/White	Orange/White
Reverse Light	(+)	Purple/White	Orange/White	Purple/White	Purple/White
E-Brake	(-)	Lt Green	Yellow/Blue	Lt Green	Lt Green
VSS (vehicle speed sensor)	(DATA)	Pink	Green/White	N/A	Pink
Power Antenna	(+)	Blue	Blue	Blue	N/A



INSTALL GUIDE SUBARU IMPREZA BASE 2012-2014

RETAINS STEERING WHEEL CONTROLS, AMPLIFIER AND MORE!



PRODUCTS REQUIRED

iDataLink Maestro RR Radio Replacement Interface
iDataLink Maestro SU1 Installation Harness

PROGRAMMED FIRMWARE

ADS-RR(SR)-SUB02A-DS

OPTIONAL ACCESSORIES



ACC-uSU1

Click here for:

[Radar Integration Installation Guide](#)

[Radar Integration Owner's Guide for Kenwood and JVC Radios](#)

WELCOME

Congratulations on the purchase of your iDatalink Maestro RR Radio replacement solution. You are now a few simple steps away from enjoying your new car radio with enhanced features.

Before starting your installation, please ensure that your iDatalink Maestro module is programmed with the correct firmware and that you carefully review the Installation Diagram and Vehicle Wire Reference Chart.

Please note that Maestro RR will only retain functionalities that were originally available in the vehicle.

NEED HELP?

 **1 866 427-2999**

 maestro.support@adsdata.ca

 maestro.idatalink.com/support
www.12voltdata.com/forum

TABLE OF CONTENTS

Installation Instructions	3
Wiring Diagram	4
Radio Wire Reference Chart	5

INSTALLATION INSTRUCTIONS

STEP 1

- Unbox the aftermarket radio and locate its main harness.
- Cut the WHITE, GRAY, GREEN and PURPLE RCA tips.
- Connect the wires from aftermarket radio main harness to the SU1 T-harness and match the wire functions.
- Remove the factory radio.

STEP 2

- Assemble the SU1 T-harness and connect it to the factory radio harness.

STEP 3

- Plug the OBDII connector into the OBDII of the vehicle, under driver dash.

STEP 4

- Plug the aftermarket radio harnesses into the aftermarket radio.
- Plug the Data cable to the data port of the aftermarket radio.
- Insert the Audio cable into the iDataLink 3.5 mm audio jack of the aftermarket radio.

STEP 5

- Connect all the harnesses to the Maestro RR module then test your installation.

TROUBLESHOOTING TIPS:

- To reset the module back its factory settings, turn the key to the OFF position then disconnect all connectors from the module. Press and hold the module's programming button and connect all the connectors back to the module. Wait, the module's LED will flash RED rapidly (this may take up to 10 seconds). Release the programming button. Wait, the LED will turn solid GREEN for 2 seconds.
- For technical assistance call 1-866-427-2999 or e-mail "maestro.support@idatalink.com". Visit us at "maestro.idatalink.com/support" and "www.12voldata.com/forum/"

WIRING DIAGRAM

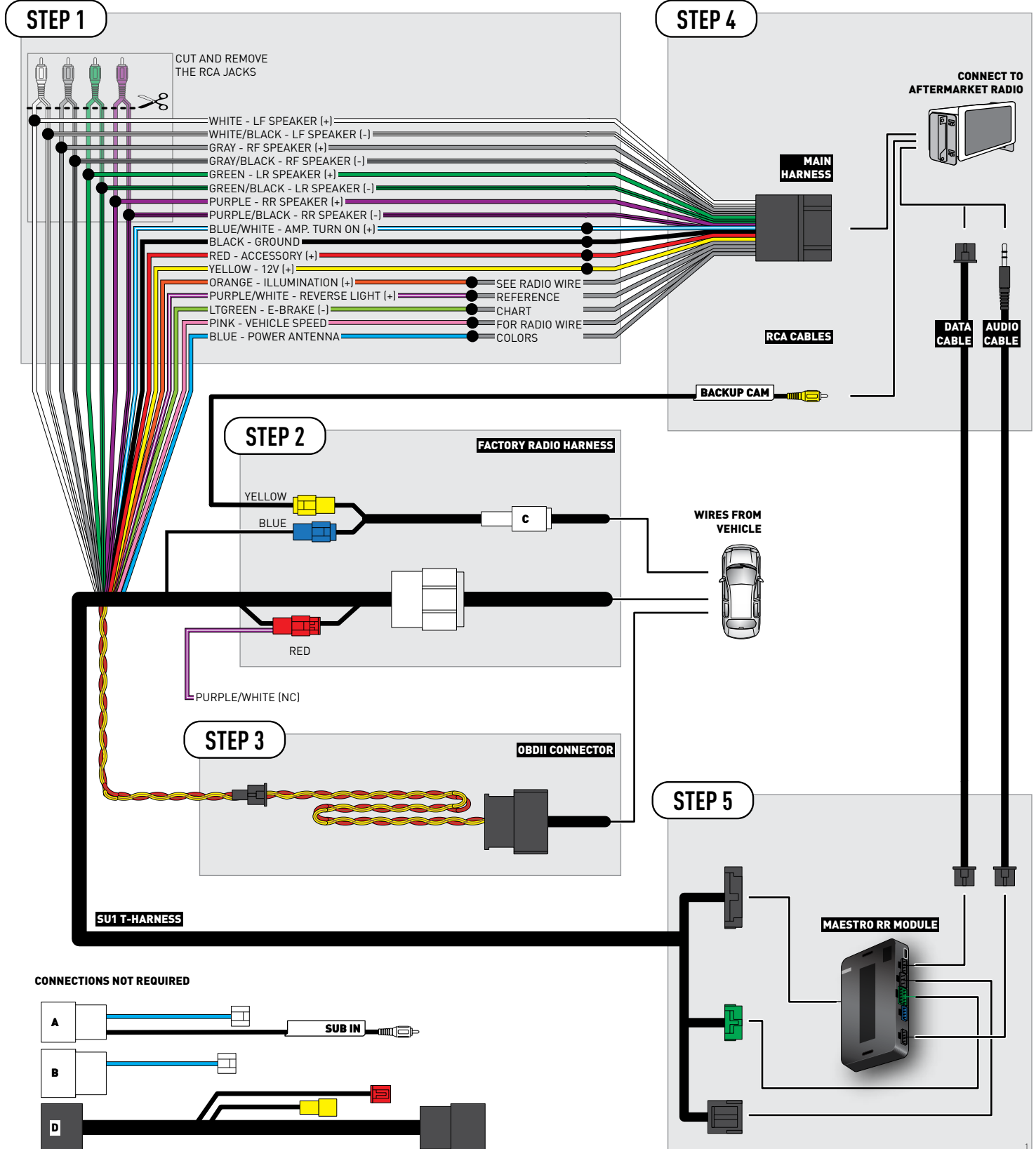

RADIO WIRE REFERENCE CHART

Wire Description	Polarity	Wire Color on Maestro T-Harness	Wire Color on Alpine cable	Wire Color on Kenwood cable	Wire Color on Pioneer cable
Illumination	(+)	Orange	N/A	Orange/White	Orange/White
Reverse Light	(+)	Purple/White	Orange/White	Purple/White	Purple/White
E-Brake	(-)	Lt Green	Yellow/Blue	Lt Green	Lt Green
VSS (vehicle speed sensor)	(DATA)	Pink	Green/White	N/A	Pink
Power Antenna	(+)	Blue	Blue	Blue	N/A



INSTALL GUIDE SUBARU WRX STI WITH BLUETOOTH 2015

RETAINS STEERING WHEEL CONTROLS, AMPLIFIER AND MORE!



PRODUCTS REQUIRED

iDatalink Maestro RR Radio Replacement Interface
iDatalink Maestro SU1 Installation Harness

PROGRAMMED FIRMWARE

ADS-RR(SR)-SUB02A-DS

OPTIONAL ACCESSORIES



ACC-uSU1

Click here for:

[Radar Integration Installation Guide](#)

[Radar Integration Owner's Guide for Kenwood and JVC Radios](#)

WELCOME

Congratulations on the purchase of your iDatalink Maestro RR Radio replacement solution. You are now a few simple steps away from enjoying your new car radio with enhanced features.

Before starting your installation, please ensure that your iDatalink Maestro module is programmed with the correct firmware and that you carefully review the Installation Diagram and Vehicle Wire Reference Chart.

Please note that Maestro RR will only retain functionalities that were originally available in the vehicle.

NEED HELP?

 **1 866 427-2999**

 maestro.support@adsdata.ca

 maestro.idatalink.com/support
www.12voltdata.com/forum

TABLE OF CONTENTS

Installation Instructions	3
Wiring Diagram	4
Radio Wire Reference Chart	5

INSTALLATION INSTRUCTIONS

STEP 1

- Unbox the aftermarket radio and locate its main harness.
- Connect the wires from aftermarket radio main harness to the SU1 T-harness and match the wire functions.
- Remove the factory radio.

STEP 2

- Assemble the SU1 T-harness and connect it to the factory radio harness.

STEP 3

- Plug the OBDII connector into the OBDII of the vehicle, under driver dash.

STEP 4

- Plug the aftermarket radio harnesses into the aftermarket radio.
- Plug the RCA cables to the aftermarket radio.
- Plug the Data cable to the data port of the aftermarket radio.
- Insert the Audio cable into the iDataLink 3.5 mm audio jack of the aftermarket radio.

STEP 5

- Connect all the harnesses to the Maestro RR module then test your installation.

TROUBLESHOOTING TIPS:

- To reset the module back its factory settings, turn the key to the OFF position then disconnect all connectors from the module. Press and hold the module's programming button and connect all the connectors back to the module. Wait, the module's LED will flash RED rapidly (this may take up to 10 seconds). Release the programming button. Wait, the LED will turn solid GREEN for 2 seconds.
- For technical assistance call 1-866-427-2999 or e-mail "maestro.support@idatalink.com". Visit us at "maestro.idatalink.com/support" and "www.12voldata.com/forum/"

WIRING DIAGRAM

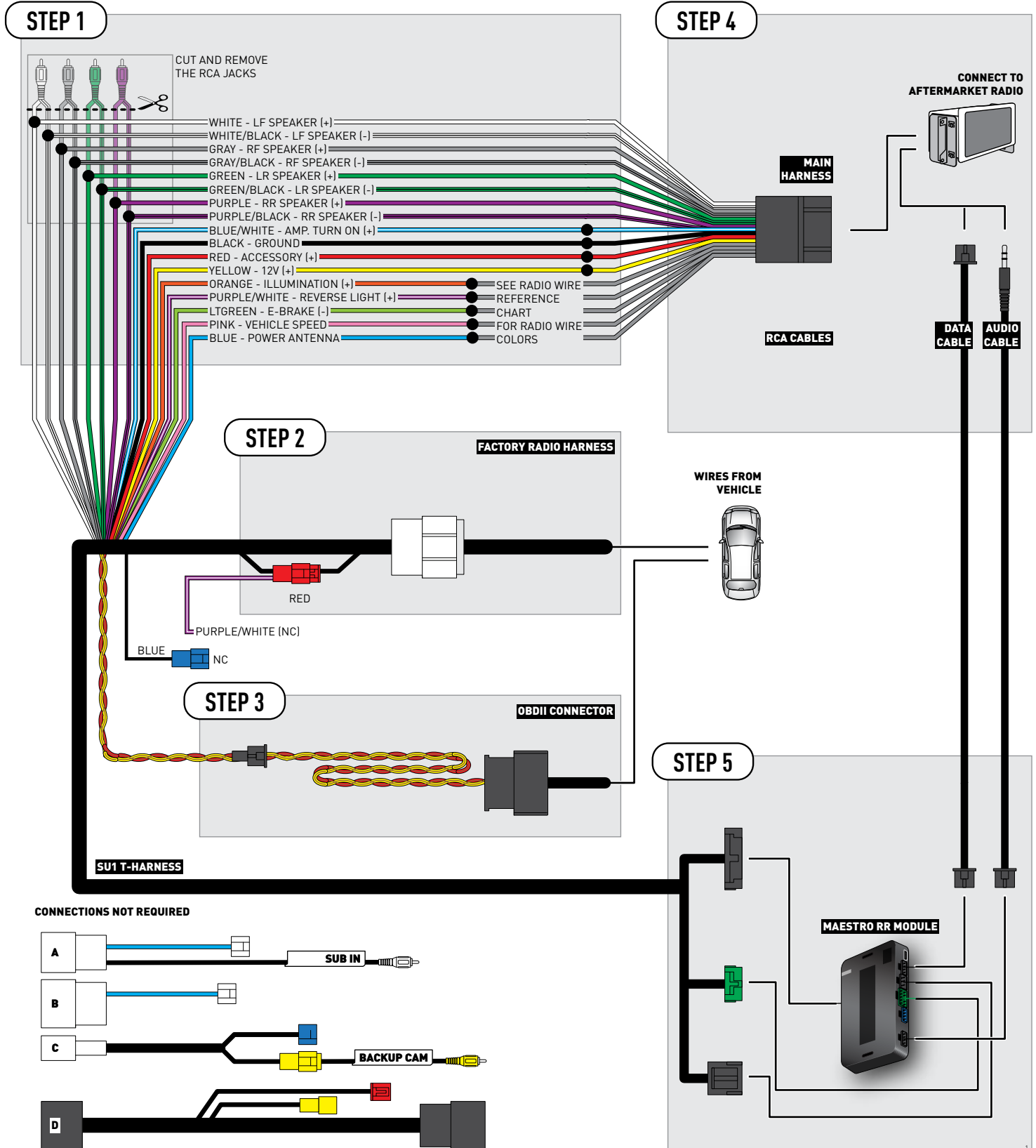

RADIO WIRE REFERENCE CHART

Wire Description	Polarity	Wire Color on Maestro T-Harness	Wire Color on Alpine cable	Wire Color on Kenwood cable	Wire Color on Pioneer cable
Illumination	(+)	Orange	N/A	Orange/White	Orange/White
Reverse Light	(+)	Purple/White	Orange/White	Purple/White	Purple/White
E-Brake	(-)	Lt Green	Yellow/Blue	Lt Green	Lt Green
VSS (vehicle speed sensor)	(DATA)	Pink	Green/White	N/A	Pink
Power Antenna	(+)	Blue	Blue	Blue	N/A



INSTALL GUIDE SUBARU WRX WITH BLUETOOTH 2015

RETAINS STEERING WHEEL CONTROLS, AMPLIFIER AND MORE!



PRODUCTS REQUIRED

iDataLink Maestro RR Radio Replacement Interface
iDataLink Maestro SU1 Installation Harness

PROGRAMMED FIRMWARE

ADS-RR(SR)-SUB02A-DS

OPTIONAL ACCESSORIES



ACC-uSU1

Click here for:

[Radar Integration Installation Guide](#)

[Radar Integration Owner's Guide for Kenwood and JVC Radios](#)

WELCOME

Congratulations on the purchase of your iDatalink Maestro RR Radio replacement solution. You are now a few simple steps away from enjoying your new car radio with enhanced features.

Before starting your installation, please ensure that your iDatalink Maestro module is programmed with the correct firmware and that you carefully review the Installation Diagram and Vehicle Wire Reference Chart.

Please note that Maestro RR will only retain functionalities that were originally available in the vehicle.

NEED HELP?

 **1 866 427-2999**

 maestro.support@adsdata.ca

 maestro.idatalink.com/support
www.12voltdata.com/forum

TABLE OF CONTENTS

Installation Instructions	3
Wiring Diagram	4
Radio Wire Reference Chart	5

INSTALLATION INSTRUCTIONS

STEP 1

- Unbox the aftermarket radio and locate its main harness.
- Connect the wires from aftermarket radio main harness to the SU1 T-harness and match the wire functions.
- Remove the factory radio.

STEP 2

- Assemble the SU1 T-harness and connect it to the factory radio harness.

STEP 3

- Plug the OBDII connector into the OBDII of the vehicle, under driver dash.

STEP 4

- Plug the aftermarket radio harnesses into the aftermarket radio.
- Plug the RCA cables to the aftermarket radio.
- Plug the Data cable to the data port of the aftermarket radio.
- Insert the Audio cable into the iDataLink 3.5 mm audio jack of the aftermarket radio.

STEP 5

- Connect all the harnesses to the Maestro RR module then test your installation.

TROUBLESHOOTING TIPS:

- To reset the module back its factory settings, turn the key to the OFF position then disconnect all connectors from the module. Press and hold the module's programming button and connect all the connectors back to the module. Wait, the module's LED will flash RED rapidly (this may take up to 10 seconds). Release the programming button. Wait, the LED will turn solid GREEN for 2 seconds.
- For technical assistance call 1-866-427-2999 or e-mail "maestro.support@idatalink.com". Visit us at "maestro.idatalink.com/support" and "www.12voldata.com/forum/"

WIRING DIAGRAM

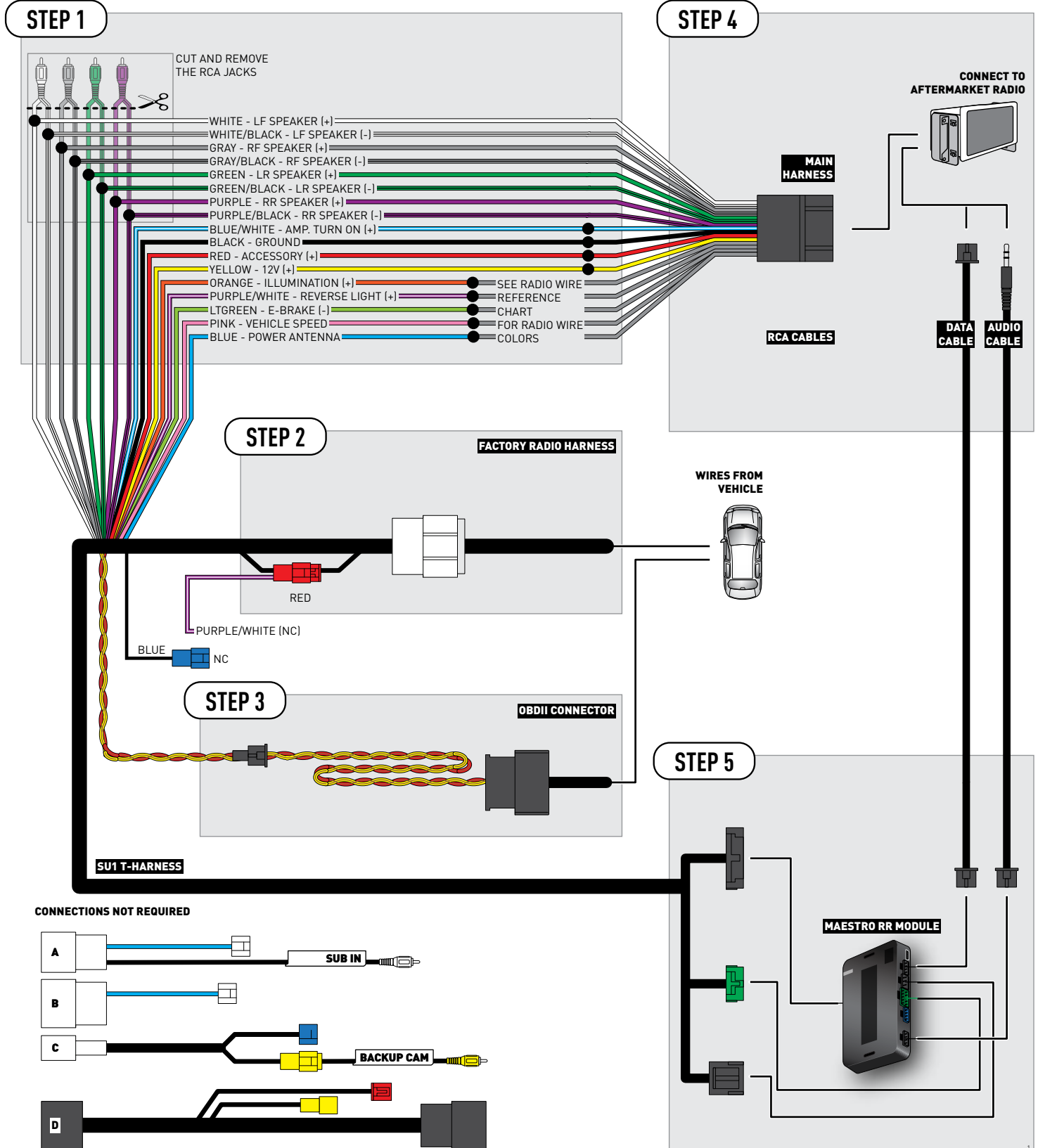

RADIO WIRE REFERENCE CHART

Wire Description	Polarity	Wire Color on Maestro T-Harness	Wire Color on Alpine cable	Wire Color on Kenwood cable	Wire Color on Pioneer cable
Illumination	(+)	Orange	N/A	Orange/White	Orange/White
Reverse Light	(+)	Purple/White	Orange/White	Purple/White	Purple/White
E-Brake	(-)	Lt Green	Yellow/Blue	Lt Green	Lt Green
VSS (vehicle speed sensor)	(DATA)	Pink	Green/White	N/A	Pink
Power Antenna	(+)	Blue	Blue	Blue	N/A